

### GENERAL DESCRIPTION

The wireless battery powered output module allows the activation, deactivation or switching of circuits and devices connected to its outputs. The activation-switching command is sent from the control panel to the module via the wire to wireless translator and other possible wireless expander devices.

The wireless battery powered module is designed with the following outputs:

- a 12 V<sub>dc</sub> / 24 V<sub>dc</sub> output
- a relay switch output.

Communication between the module and its translator or expander is wireless, via "Sagittarius" protocol.



Picture 1 - General view of the product

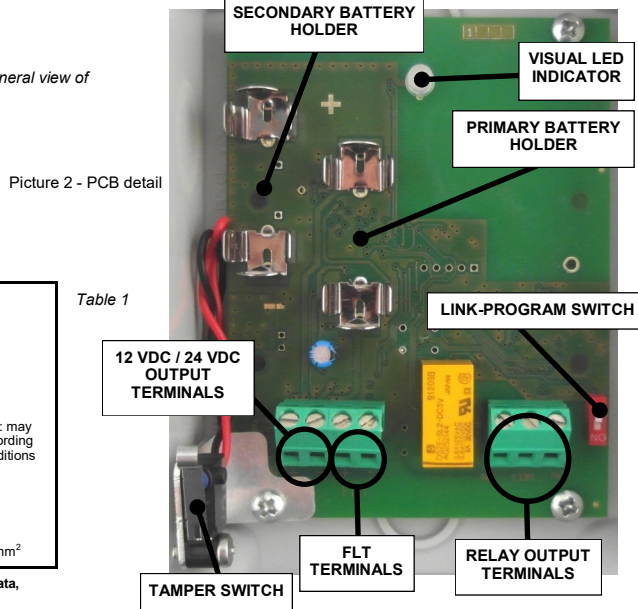

Picture 2 - PCB detail

TECHNICAL SPECIFICATIONS *	
Operating frequency range	868 MHz
Max radiated power	5 dBm (3 mW)
Radio signal's modulation type	FSK
Operating frequency channels	7
Module's communication range with its parent translator or expander in open space	200 m. Ideal operating range: may vary consistently according to environmental conditions
Max tolerated humidity (no condensing)	95% RH
IP rating	65
Cable entry knockout holes specifications	6 x M16/20
Applicable wire gauge range to terminal blocks	from 0.5 mm <sup>2</sup> to 2.5 mm <sup>2</sup>

\* Check latest version of document TDS-SGMCB2 for further data, obtainable from your supplier.

BATTERY SPECIFICATIONS	
Main battery type	CR123A (3 V & 1.2 Ah)
Secondary battery type	CR123A (3 V & 1.2 Ah)
Batteries service life *	> 4 years **
Reserve service life *	2 months **

\* When a low battery condition is indicated, both, main and secondary, batteries must be changed altogether.

\*\* These lifespan values refer to the device being programmed with a control signals transmission period of 12 seconds.

If the 12 Vdc / 24 Vdc output is activated for 30 seconds a week for test, the primary battery's lifespan reduces to 3 years.

RELAY SPECIFICATIONS	
Maximum switched voltage	30 V <sub>dc</sub>
Maximum switched current	2 A
Maximum switched power	60 W

Table 3



Power source type ES1, PS2

### MODULES VISUAL LED INDICATOR

The wireless battery powered output module is equipped with a bi-colour LED (red / green) that provides visual indication for functional conditions and battery levels as indicated in table 7.

### DEVICE'S POWER SUPPLY AND LINKING

The linking operation permits the configuration of the battery powered output module on the wireless system. The linking operation described below does not change if made directly from the wire to wireless translator module's interface or from the Wirelex PC configuration program.

- 1) Move the "link-program" switch to position ON.
- 2) Insert the secondary battery into its holder.
- 3) Insert the primary battery into its holder; the visual LED indicator switches on accordingly (see "Power up" in table 7).

Ensure that both battery's polarity are correct!!!

- 4) When the translator module (by itself or piloted by the Wirelex) is searching for a new device for linking, move the "link-program" switch to position 1 in order to initiate communication with the translator module; the visual LED indicator switches on accordingly (see "Programming and linking to the system" in table 7).

### IMPORTANT NOTE!

Programming is considered to be completed successfully only if there is an indication of programming success on the translator or on the window of the Wirelex program. If the linking and programming operation fails, check if mistakes were made with the translator or the Wirelex, remove the batteries, change over alternatively the ON / 1 switch a few times in order to discharge the internal capacitor and then start again from point 1) re-performing the linking procedure.

### COMMUNICATION QUALITY ASSESSMENT

It is possible to assess the wireless communication quality between the battery powered output module and the wire to wireless translator module / wireless expander module by using a testing feature built in the device. After a successful linking operation, by changing the "link-programming" switch on the ON position, the device's LED will start blinking according to table 8.

Always remember to reposition the switch to 1 after the assessment operation: device will NOT work operatively while the switch is set on the ON position.

Communication quality	Assessment	Device's indication
No connection	Fail	Two red blinks
Link margin is less than 10 dB	Poor	One red blink
Robust communication with link margin from 10 dB to 20 dB	Good	One green blink
Robust communication with link margin over 20 dB	Excellent	Two green blinks

Table 8

### WARNINGS AND LIMITATIONS

Our devices use high quality electronic components and plastic materials that are highly resistant to environmental deterioration. However, after 10 years of continuous operation, it is advisable to replace the devices in order to minimize the risk of reduced performance caused by external factors. Ensure that this device is only used with compatible control panels. Detection systems must be checked, serviced and maintained on a regular basis to confirm correct operation.

Smoke sensors may respond differently to various kinds of smoke particles, thus application advice should be sought for special risks. Sensors cannot respond correctly if barriers exist between them and the fire location and may be affected by special environmental conditions.

Refer to and follow national codes of practice and other internationally recognized fire engineering standards. Appropriate risk assessment should be carried out initially to determine correct design criteria and updated periodically.

### WARRANTY

All devices are supplied with the benefit of a limited 3 years warranty relating to faulty materials or manufacturing defects, effective from the production date indicated on each product. This warranty is invalidated by mechanical or electrical damage caused in the field by incorrect handling or usage.

Product must be returned via your authorized supplier for repair or replacement together with full information on any problem identified.

Full details on our warranty and product's returns policy can be obtained upon request.



Hyfire Wireless Fire Solutions Limited - Unit B12a, Holly Farm Business Park, Honiley, Warwickshire, CV8 1NP - United Kingdom

EN 54-18:2005

EN 54-25:2008

HFW-BOM-03

For use in compatible fire detection and alarm system

## DEVICE'S PLACEMENT

For specific information regarding detector and device's spacing, placement and special applications refer to your specific national standards. In order to avoid a consistent degradation of the distance and quality of the wireless communication between the output module and the translator / expander module, place the output device as far as possible from metal objects (for example metal doors, windows, openings etc.), other electronic devices, computer equipment and cable conductors. For the purpose of maintaining a good communication quality, it is very important to install the output module perfectly vertically straight as illustrated in picture 2. Follow this procedure for placing the battery powered output module:

1) Select the position of the battery powered output module before installing and fixing it. Verify, from that possible position, that the communication between the device and the wire to wireless translator module / wireless expander module is correctly established and working (see the COMMUNICATION QUALITY ASSESSMENT paragraph).

2) Install and fix the device's box in the selected position using the provided screws and their indicated lodgment holes (picture 3).

The output module is designed with 6 cable entry knockout holes, distributed on the lateral sides of the device's box, allowing sealed, gland fitted cables to be connected to the device and, at the same time, to preserve the original IP protection rating (picture 4).

3) Fit the cable's gland (or glands) into the "knocked out" device box's cable entry (or entries).

4) Feed the cables into the box, giving them sufficient length for a secure connection.

5) Extract the supply batteries from their holders on the PCB, in order to power the device off.

6) Connect the cable's terminals to the device's output terminal blocks as indicated in the following paragraphs.

7) Reinsert correctly the batteries into their PCB holders, in order to power up again the device.

8) Test the module (as described later in this manual), then install and screw securely the cover onto the module's box.



Picture 3 - Wall fixing screw entry points

Picture 4 - Cable entry knockout holes

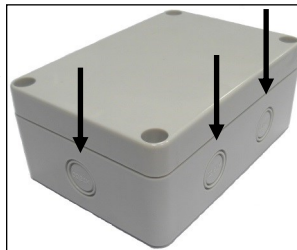

## THE 12 VDC / 24 VDC OUTPUT

The battery powered output module is equipped with a 12 V<sub>dc</sub> / 24 V<sub>dc</sub> output. The output voltage, its characteristics and behavior must be selected and programmed through the wire to wireless translator module with the sole aid of the Wirelex program.

Install the supplied additional module between this output and the external device; this module enhances stability of the output current and reduces output current loss (no EOL resistance is to be installed):

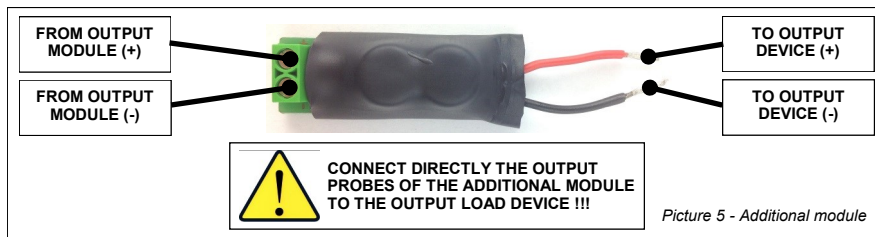

Picture 5 - Additional module

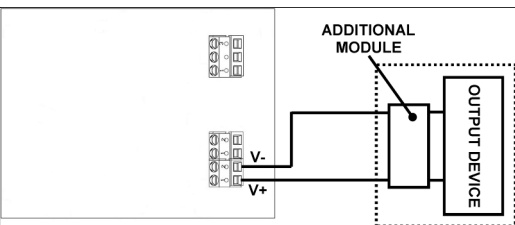

Picture 6 - Wiring example for the 12 Vdc / 24 Vdc output, with the supplied additional module used

## THE RELAY OUTPUT

The battery powered output module is equipped with a SPDT (Single Pole Double Throw) relay operated output switch; "NO" is the normally open terminal, "NC" is the normally closed terminal and "COM" is the common terminal. Consult table 3 for the relay specifications.

The output characteristics and behavior must be selected and programmed through the wire to wireless translator module with the sole aid of the Wirelex program.

An example of wiring for the relay output can be as the following:

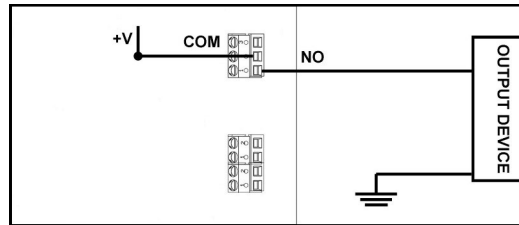

Picture 7 - Wiring example for relay switch output

## FAULT (FLT) SUPERVISORY PORT

This additional port can be used for short / open circuit supervisory purposes. Supervision is exerted through a EOL supervisory resistor (check table 5 for its recommended value) placed as follows:

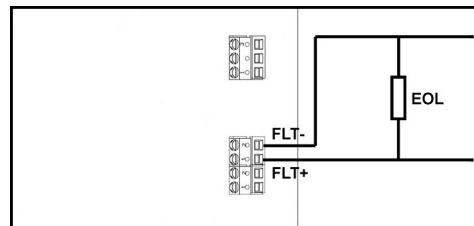

Picture 8 - Wiring example for the FLT port

It is suggested to wire the EOL as near as possible to the output module. FLT port must be enabled through Wirelex software during programming. **IMPORTANT! For this product, FLT faults are NOT signaled by the translator's display!**

## BATTERY FAULTS

If a battery fault condition is detected on the battery powered output module, a fault message is sent to the control panel via the wire to wireless translator module / wireless expander module. This kind of fault condition is locally signaled by the module's visual LED indicator (see table 7).

## TAMPER DETECTION FEATURE

The wireless battery powered output module is provided with a tamper detection switch, and, in case of removal of the cover from its box, it sends a tamper detection message to the control panel. For this reason assure that the front cover is well inserted and closed.

**IMPORTANT! For this product, tamper detection event is NOT signaled by the translator's display!**

## TESTING

In order to test the functionality of the installed battery powered output module, the following test must be performed: activate an alarm condition on the control panel (by a call-point or sensor in the installed system); the control panel will transmit an activate / switch message to the module via the wire to wireless translator / the wireless expander and activate / switch the module's outputs; this applies to the 12 Vdc / 24 Vdc and the relay outputs. After each test the device must be reset from the control panel (see the RESET paragraph).

If the test fails, check whether the batteries are charged, if mistakes were done previously or even if the system is activated. If the battery powered output module functionality is hopeless, send back the device to your distributor for repair or substitution.

**All devices must be tested after installation and, successively, on a periodic basis.**

## RESET

To reset the battery powered output module from an activated / switched status, it is necessary to send the reset command from the control panel: outputs will deactivate.

## MAINTENANCE

- 1) Before starting any maintenance work (e.g. batteries substitution), disable the system in order to avoid accidental and unwanted fault detection conditions.
- 2) Remove the front cover from the device's box.
- 3) Perform the planned necessary maintenance operations.
- 4) After the device has been serviced, reinstall correctly the front cover onto its box, reactivate the system and check correct operation as described under the TESTING paragraph.