

DATASHEET  
**HYFIRE TAURUS**  
**BLACK OPTICAL DETECTOR**  
TAU-OP-01-BL

**TAURUS**   
By Hyfire

The TAU-OP-01-BL Hyfire Taurus Black Optical Detector is the latest in wireless smoke detector technology. The detector utilises dual optical smoke detection technologies and algorithms for improved performance, maintaining the highest levels of false alarm rejection. Utilising well-proven adaptive radio signal processing algorithms it ensures the highest levels of life safety and system reliability are achieved. In-built magnet test allows easy activation to verify correct functionality and response.



### KEY FEATURES

- Advanced dual optical chamber design
- Dual angle scattering analysis
- Advanced drift compensation
- Bi-directional wireless communication
- Can be used with Taurus addressable and conventional translators
- 22 pairs of field channels
- Dual channel redundancy
- Long communication range ( $\cong 1$  km in open air)
- 10 year battery life
- Utilises standard low-cost lithium battery technology
- Device identification tab
- Fast test feature for engineer testing
- Easy scan & link programming option
- Security screw to prevent tampering and unwanted removal
- 3rd party approval to EN54-7 and EN54-25
- 5 year product warranty
- Tri-coloured LED

### TECHNICAL SPECIFICATION

|                               |                |
|-------------------------------|----------------|
| Operating frequency range     | 868 – 870 MHz  |
| Max radiated power            | 14dBm (25mW)   |
| Dimensions                    | 110mm x 70mm   |
| Weight (without batteries)    | 155 g          |
| Batteries                     | 2x CR123A      |
| Operating Temperature         | -10°C to +55°C |
| Max humidity (non condensing) | 95% RH         |
| IP rating                     | 40             |

### TECHNICAL INFORMATION

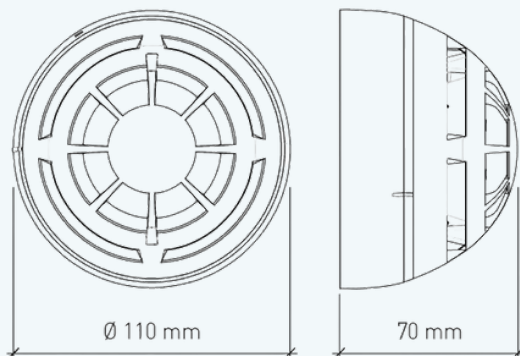

### STANDARDS & APPROVALS

- BS EN54-7 Smoke Detectors
- BS EN54-25: Components using radio links



DATASHEET  
**HYFIRE TAURUS**  
**BLACK OPTICAL DETECTOR**

**TAURUS**   
By Hyfire

**BASE COMPATIBILITY**

---

This device is supplied with a standard base and is compatible with the following sounder bases:

- TAU-BS-01-BL Hyfire Taurus Black Sounder Base
- TAU-BSB-23W-01-BL Hyfire Taurus Black Sounder VAD Base (White Flash) (EN54-23 approved)

