

HFW-W2W-E-01

WIRELESS ENHANCED TRANSLATOR MODULE (LOOP POWERED)

INSTALLATION INSTRUCTIONS



928r/05

WARNINGS AND LIMITATIONS

Our devices use high quality electronic components and plastic materials that are highly resistant to environmental deterioration. However, after 10 years of continuous operation, it is advisable to replace the devices in order to minimize the risk of reduced performance caused by external factors. Ensure that this device is only used with compatible control panels. Detection systems must be checked, serviced and maintained on a regular basis to confirm correct operation. Smoke sensors may respond differently to various kinds of smoke particles, thus application advice should be sought for special risks. Sensors cannot respond correctly if barriers exist between them and the fire location and may be affected by special environmental conditions. Refer to and follow national codes of practice and other internationally recognized fire engineering standards. Appropriate risk assessment should be carried out initially to determine correct design criteria and updated periodically.

WARRANTY

All devices are supplied with the benefit of a limited 5 years warranty relating to faulty materials or manufacturing defects, effective from the production date indicated on each product. This warranty is invalidated by mechanical or electrical damage caused in the field by incorrect handling or usage. Product must be returned via your authorized supplier for repair or replacement together with full information on any problem identified. Full details on our warranty and product's returns policy can be obtained upon request.



2831/0051/0681

0832

15

21

HF-20-035CPR

HF-20-035UK

Hyfire Wireless Fire Solutions Limited - Unit B12a,
Holly Farm Business Park, Honiley, Warwickshire,
CV8 1NP - United Kingdom

EN 54-18:2005

EN 54-25:2008

HFW-W2W-E-01

For use in compatible fire detection and alarm system

GENERAL DESCRIPTION

The wire to wireless translator module is a device which interfaces the hard wired, Vega intelligent-analogue loop to the Sagittarius wireless system *. It actually simply expands the analogue system, permitting the addition of fire detecting devices based on the Sagittarius wireless communication protocol for monitoring and control.

The wireless system that stems from this translator model can host up to 127 wireless child devices, utilizing up to 128 analogue addresses (if we consider the address assigned to the translator itself); its “dynamic routing” feature adds a big deal of reliability in case of accidental loss of communication with its expander devices due to interfering environmental factors.

The translator, as any other Vega device, is powered directly by the analogue loop, and is to be used with control panels that implement the Vega communication protocol for monitoring and control; as a matter of fact its main function is to act literally as a translator between the Vega and the Sagittarius protocols.

* Vega indicates a family of addressable, hard-wired connectable, analogue-intelligent devices used in the fire detecting field which can dialogue with a control panel by the means of an adequate communication protocol. These devices use the Vega protocol.

Sagittarius indicates a family of addressable, wireless connectable, analogue-intelligent devices used in the fire detecting field which can dialogue by radio with an adequate protocol translator which permits the managing of those devices by a hard-wired connected control panel as if they were part of the detecting line. These devices use the Sagittarius protocol.

Note: The latest release of the wireless system configuration software is available from the manufacturer’s website.

DEVICE'S OVERVIEW

Following is an overview of the translator: picture 1 for a front view of the device; picture 2 for an inside view; picture 3 for its dimensions; table 1 for its technical specifications.



Picture 1 - device overview

Table 1

TECHNICAL SPECIFICATIONS **	
Loop power supply range	 from 18V _{ac} to 40V _{ac}
Typical current consumption	20mA (at 24V _{ac})
Operating frequency range	868.15 MHz - 869.85 MHz
Radiated power range	5 dBm (3 mW)
Radio signal's modulation type	FSK
Number of frequency channels	7
Communication range with a wireless expander device	600 m (in open space) *
Communication range with other wireless devices	200 m (in open space) *
Maximum linked wireless devices	127 (128 addresses including the translator)
Maximum linked wireless expander devices	15
Maximum child devices per translator and per every single expander device	32
Maximum output devices (output modules, sounders...) per translator and per every single expander device	16
Temperature range	from -30°C to +50°C
Tolerated humidity range (no condensing)	from 5% RH to 90% RH
Dimensions (without antennas)	120 mm x 160 mm x 51 mm
Number of antennas	2
External antenna's length	74 mm
Weight	300 g

* Ideal operating range; may vary consistently according to environmental conditions.

** Check latest version of document TDS-VW2W128 for further data, obtainable from your supplier.



Power source type ES1, PS2

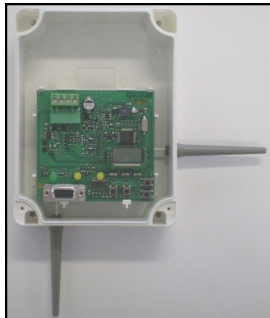

Picture 2 - device's inside view

Picture 3 - device dimensions

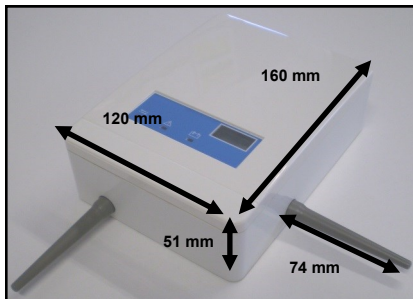

PART 1 - SURFACE INSTALLATION

DEVICE POSITIONING FOR RADIO COMMUNICATION PERFORMANCE AND STABILITY

The translator must have a good radio communication with its wireless system's devices. In order to achieve this, before positioning it and installing it, apply scrupulously the following points:

- select, for the translator, a radio channel that is free or relatively free of other signals; avoid, if possible, used channels. In order to obtain this, use the supplied RF-Analyze program.

Identify the translator's wireless system with a unique system number.

For more data about radio channels and system identification refer to the programming section.

- Avoid installing the translator close to:
 - equipment using large amounts of electrical current
 - large metal objects, structures or metal ceiling structures
 - fluorescent lighting fixings
 - computers, their cabling and network cabling.
- If there are other translators or wireless system expander modules, keep a distance between them of at least 2 metres. In general every installed radio device (child devices included) must have a minimum distance of at least 2 metres from each other.
- It is recommended to install the translator and expanders at an height from the floor of at least 2 - 2.5 metres.
- Install the translator perfectly flat on the wall.

- The translator must be installed perfectly straight on the wall; this means that the antenna under the device must be perpendicular to the floor and the antenna on the right of the device must be parallel to the floor.

- Environmental parameters (temperature, humidity and so on) must be in the ranges specified in the translator's technical specifications, which can be found at the beginning of this manual; this point applies, obviously, to all wireless devices.

- After having installed the translator, make sure that the translator's child devices (sensors, call points, etc.) are reached by a good, strong signal (refer to the single device's manuals) in their position of installation.

Radio transmission ranges for the translator can found in the technical specifications at the beginning of this manual.

- IF THE SYSTEM EMPLOYS EXPANDER MODULES, THE WIRELESS SOFTWARE MUST BE USED TO CONFIGURE THE SYSTEM. THE LOCAL PROGRAMMING FACILITY ON THE TRANSLATOR MODLE CANNOT BE USED!

INSTALLING THE ANTENNAS TO THE TRANSLATOR

In the case that the antennas are delivered separate from the main device, these need to be connected to it.

The translator device is composed by 2 PCBs: the outer one is the Vega protocol interface PCB and the inner one is the radio frequency, Sagittarius-protocol one. Antennas must be securely connected to the Sagittarius PCB, and, specifically, to the connecting terminal blocks (picture 4).

- First of all uninstall the Vega PCB from the device by lifting the blocking plastic hooks and by pulling out the circuit board; during this operation do not disconnect the flat cable connecting the two PCBs.

- One by one, for every antenna, insert the conductive end of them into the device's lateral holes and, then, into the relative Sagittarius PCB's terminal blocks, exactly as shown in picture 4.

- Securely screw the antenna endings to the terminal blocks into which they have been fitted in, and ensure that the antennas are secure and perpendicular to their corresponding device's lateral surface plane.

- Reinstall securely and correctly the front Vega PCB into the device, checking that the flat cable has not been accidentally disconnected.

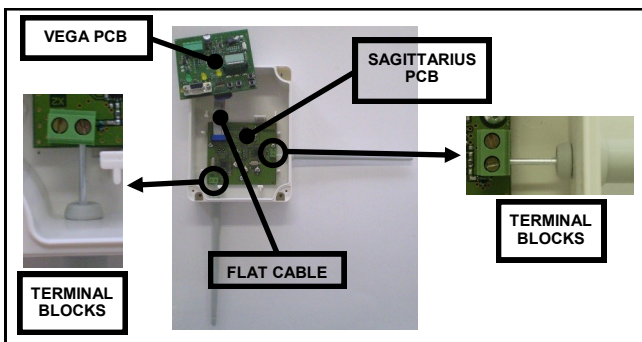

Picture 4 - antennas installation

SURFACE INSTALLATION PROCEDURE

The translator's circuitry is already equipped with its own surface mounting box, designed with four 20 mm breakable entry holes (two at the top and two on the upper side of the rear of the box), allowing sealed, cable gland fitted, loop cables to be connected to the device (see picture 5).

- Find a suitable location for the translator.
- Drill the required number of holes on the wall (see picture 6 for an indication of the screw inserting locations on the box and figure 7 for an indication of their distances between each other and their diameter).
- Prepare the cable openings on the box.
- Securely and adequately fix the device's box to the wall with adequate screws (DO NOT use the countersunk type).

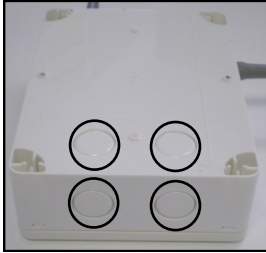

*Picture 5 -
breakable
wire entry
holes*

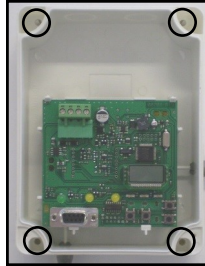

*Picture 6 -
wall fixing
screw holes*

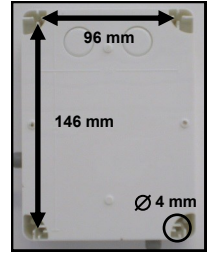

*Picture 7 -
distances
between
wall fixing
screw holes
and their
diameter*

PART 2 - WIRING

TRANSLATOR' S WIRING

For wiring bear in mind the following points:

- Refer to and follow national codes of wiring and cabling practice and other internationally recognized standards.
- Loop terminals are polarity sensitive, so connect them adequately according to the following instructions.

Fit an adequate cable gland to the loop's cables and apply it to the entry hole; successively feed the wires into the box, giving them sufficient length to be connected to the device's terminals. If other knockout holes have been opened, seal them with blanking glands in order to maintain the device's original IP rating.

Connect the analogue loop's cable to the device's terminal blocks as wiring scheme in picture 8 and table 2.

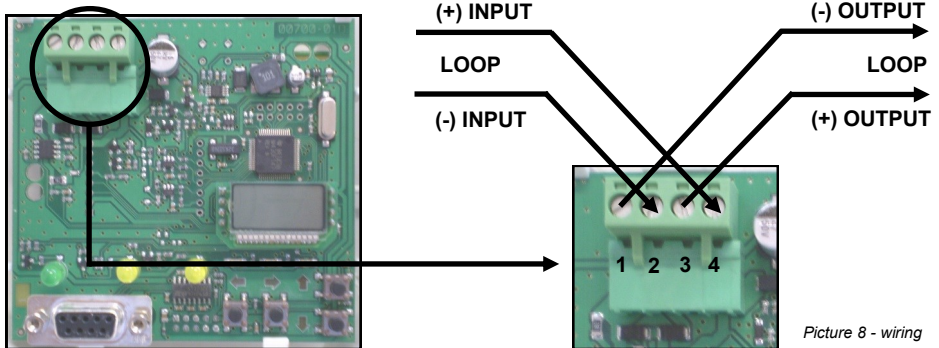

Picture 8 - wiring

Terminal	Function	Description	Comment
1	Line - out	Line negative out	Short circuit protected
2	Line - in	Line negative in	Short circuit protected
3	Line + out	Line positive out	
4	Line + in	Line positive in	

Table 2

SHORT CIRCUIT ISOLATORS

All standard Vega analogue devices (but not the Vega Lite series devices) are equipped with integrated short circuit isolators which monitor the analogue loop and can be activated by the control panel.

WARNING
Disconnect loop power before installing the translator



CAUTION
Electrostatic sensitive device. Observe precautions when handling and making connections

PART 3 - INSTALLATION COMPLETION

TRANSLATOR'S INSTALLATION COMPLETION

Configure the radio system either directly on the translator via its keyboard / display system or through a personal computer connected to it via RS232. System's configuration programming will be described later in this manual.

Mount the device's cover over its box, inserting the upper side first (see picture 9). Securely screw the cover on the box by inserting the supplied screws into the front cover's holes (see picture 10).

Insert the plastic mask onto the front plastic cover (see picture 10).

After having installed the system remember to check the translator's effectiveness; translator testing will be described later in this manual.

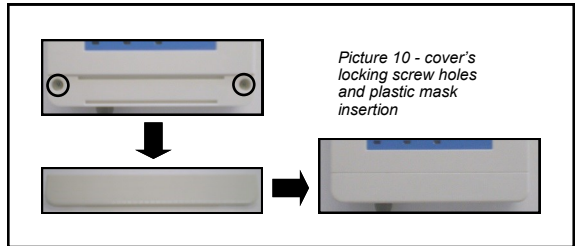
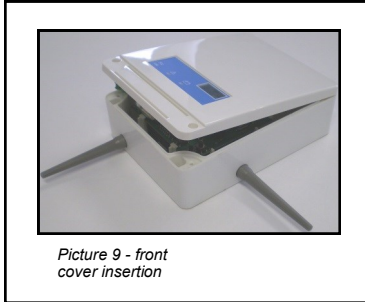

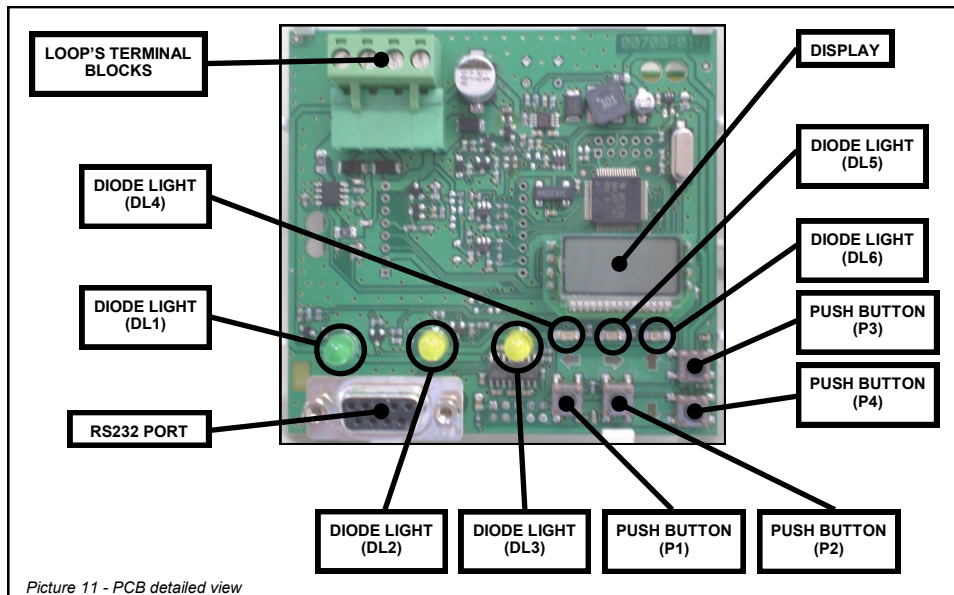

Picture 11 - PCB detailed view

TRANSLATOR'S COMMANDS, DISPLAYS AND CONNECTIONS GENERAL DESCRIPTION

LOOP TERMINAL BLOCKS: used to connect the translator to the analogue loop.

DISPLAY: indicates translator's status messages, alarm messages and it is used to configure the wireless system.

RS232 PORT: by connecting this port to a personal computer via serial wire, it is possible to configure the wireless system using the Wirelex software

DIODE LIGHT (DL1): green colour (blinking): indicates that the translator is being polled by the analogue control panel.

DIODE LIGHT (DL2): yellow colour: indicates that the translator or a system's device is in a radio fault condition; **it also indicates that a wireless device has lost communication with the translator.**

DIODE LIGHT (DL3): yellow colour: indicates that a wireless device connected to the translator has a low battery.

DIODE LIGHT (DL4): red colour: indicates that the translator is searching for a wireless device; in particular, it switches on during the linking and addition phase of a radio device to the wireless configuration.

DIODE LIGHT (DL5): red colour: indicates that a device type, shown on the display, corresponding to a certain address, is configured on the wireless system (activates only when the LIST command is in use).

DIODE LIGHT (DL6): not used.

PUSH BUTTON (P1): used to exit out from a menu or sub-menu; exit from a sub-menu if the operator does not accept the changes made.

PUSH BUTTON (P2): used to enter into a menu or sub-menu; confirm the changes made to parameters.

PUSH BUTTON (P3): used to navigate through menus or sub-menus; change parameters (value increase).

PUSH BUTTON (P4): used to navigate through menus or sub-menus; change parameters (value decrease).

TRANSLATOR'S WIRELESS SYSTEM CONFIGURATION PROGRAMMING

The wireless system configuration can be programmed in these ways:

- by using the Wirelex software installed on a personal computer connected to the translator via RS232 serial port.
THIS APPROACH IS MANDATORY IF THERE IS AT LEAST ONE EXPANDER MODULE IN THE SYSTEM!

- By using the keys and display on the device.
THIS APPROACH MUST NOT BE USED IF THE SYSTEM EMPLOYS ONE OR MORE EXPANDER MODULES!

For the Wirelex configuration simply connect the personal computer's serial port to the RS232 port on the translator; install the Wirelex software on the PC and follow the instructions on the Wirelex manual.

The present manual describes only the system's configuration through the usage of the translator's display and command keys.

For the definition of the meanings of the display messages refer to Appendix A.

For a reference to the general menu, sub-menu and command structure of the translator refer to Appendix C.

Accessing a menu or sub-menu disables the main control panel's Vega protocol communication; it can be restored by returning to a BLANK display or by not touching the keypad for 90 seconds.

NOTE ON THE WIRELESS SAGITTARIUS EXPANDER

The wireless Sagittarius expander (device designed to expand the wireless system area) can be configured and administered ONLY through the use of the Wirelex program. Refer to Wirelex and expander's documentation for having more information.

TRANSLATOR DEVICE ADDRESSING

The installer must give directly to the translator a Vega loop analogue address through the SA command (Starting Address).

When commanded to do so by the installer, the analogue control panel will successively achieve, on its configuration, the addresses of the wireless system's devices starting from the one of the translator; for example the translator has an address of 001 (given through the SA command); two wireless devices are linked to it: as a consequence the control panel will configure its system configuration with address 001 (translator) and the other two wireless devices with 002 and 003 addresses respectively.

For addressing specifications (maximum number of devices, etc.) refer to the TECHNICAL SPECIFICATIONS table given at the beginning of the manual.

There is no need to preserve 128 analogue addresses for the wireless system stemming from the translator if many of them will remain unused, but it is necessary to preserve the addresses that will be actually used.

In order to address manually the translator follow this procedure, starting from the initial blank display; bear in mind that if the address is not specified, the device will preserve its previous address value.

Starting address (SA) 255 must not be used at the moment.

SA must be set to <240.

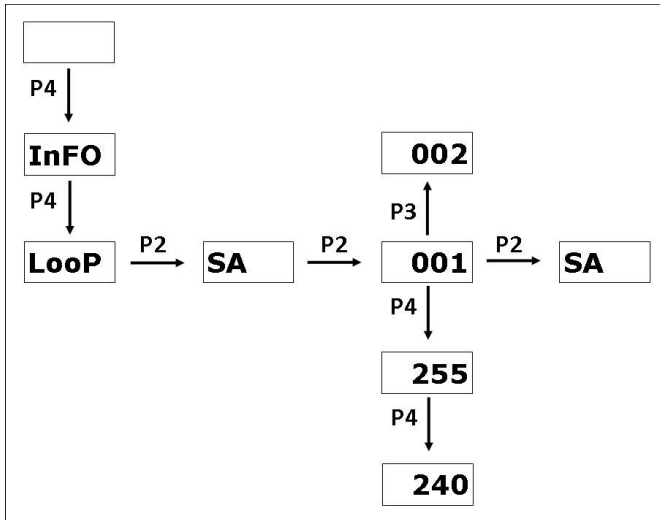

TRANSLATOR'S CHANNEL SELECTION

The translator must operate on one of the 7 prearranged channels; it must be specified if you want a radio channel for data interchange different from the default 001. Channel range span from 001 to 007. The procedure to be used is the following:

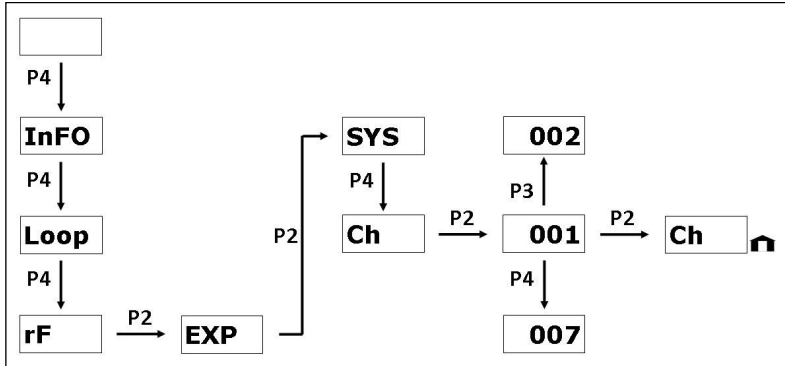

As can be seen, after channel selection, a little house icon appears on the lower right side of the display; this indicates the user that the translator's parameters have been changed.

Those changes can be discarded by pressing the P1 button.

If the user wants to keep them and make other changes he can still use the EXP sub-menu's commands (with the house icon still present).

In order to make the radio frequency channel parameter change effective, the INIT command must be used (the house icon must be still present); please read carefully THE INIT COMMAND paragraph.



WARNING!

USING THE INIT COMMAND WILL CAUSE THE WHOLE SYSTEM CONFIGURATION TO BE ERASED!



TRANSLATOR'S SYSTEM SELECTION

More than one translator can operate on a single channel; to do so it is advisable that each Translator Module employs a unique system configuration code in order to avoid data interchange conflicts between radio devices.

For instance: on channel 3 are operating 3 translators: alpha, beta and gamma, and everyone of them make up a wireless system; it is warmly advisable that every translator has its own system code: 1 for alpha, 2 for beta and 3 for gamma.

Translator design provides for 256 prearranged identifiers that range from 000 to 255; there is no default identifier, nevertheless selecting one for the system prevents potential trouble.

It is advisable not to put too many translator-wireless systems on a single channel, but to spread them across the channel range: too many systems on a single channel can be deleterious towards their efficiency.

In order to assign a system identifier to the translator follow this procedure, starting from the initial blank display:

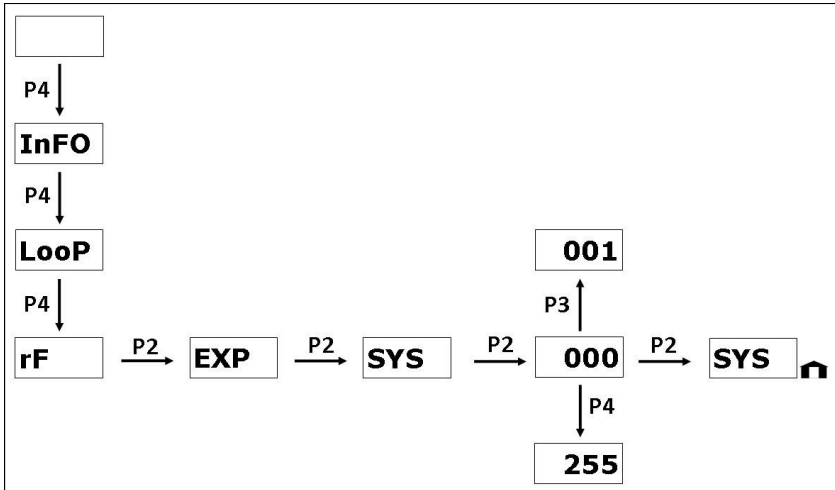



As can be seen, after the selection of the system identifier, a little house icon appears on the lower right side of the display; this indicates the user that the translator's parameters have been changed

Those changes can be discarded by the pressure of the P1 button.

If the operator wanted to keep them and make other changes he can still use the EXP sub-menu's commands (with the house icon still present).

In order to make the system identifier parameter change effective, the INIT command must be used (the house icon must be still present); please read carefully THE INIT COMMAND paragraph.

**WARNING!**

USING THE INIT COMMAND WILL CAUSE THE WHOLE SYSTEM CONFIGURATION TO BE ERASED!

THE INIT COMMAND

In order to make effective the changes made to the translator's channel and system's identifier parameters, an INIT (initialize) command must be performed.

The INIT command must not be confused with the RES (reset) command, which is used to reset the wireless system from fault or fire conditions.

In order to perform an INIT follow this procedure, starting from the EXP sub-menu's command list (with the house icon still present on the lower right side of the display).

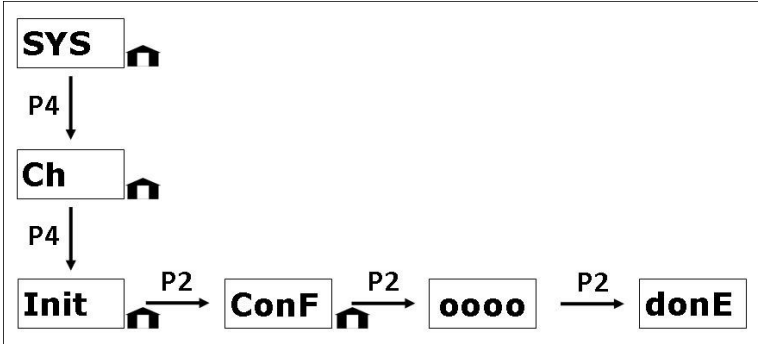

WARNING!

USING THE INIT COMMAND WILL CAUSE THE WHOLE SYSTEM CONFIGURATION TO BE ERASED!

RESETTING THE WIRELESS SYSTEM

The wireless system can be reset (from fault or fire conditions) directly from the translator, through the RES command; do not confuse this command with the INIT (initialize) command.

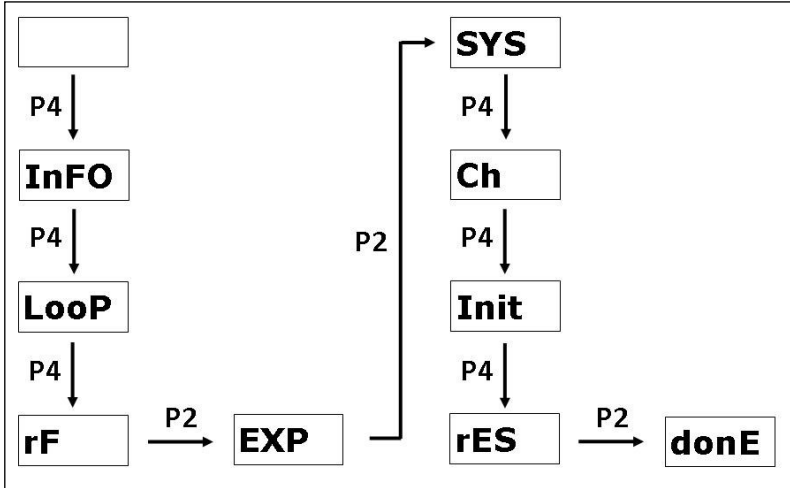

GATHERING WIRELESS SYSTEM INFORMATION: THE INFO MENU

The INFO menu is used to gather information on the configured wireless system and to retrieve the firmware version number of the Vega interface.

The command used for viewing the wireless system's devices is LIST; it gives the device type corresponding to a specific address selected by the user; when the device's type is displayed, DL5 switches on; its use is as follows:

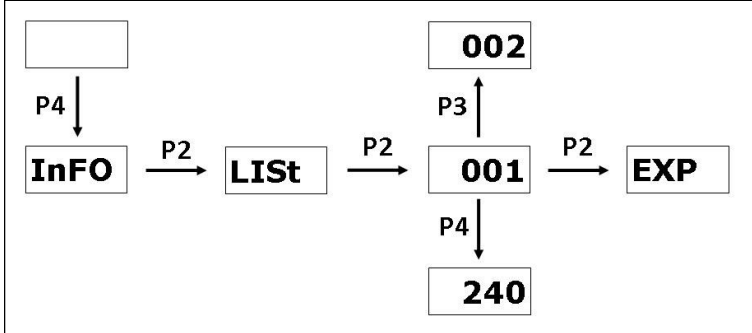

In order to retrieve the firmware's version of the device's Vega interface, the VEGA command must be used: Dots cannot be visualized on the display, so, considering the above example, the 303 should be considered as 3.03.

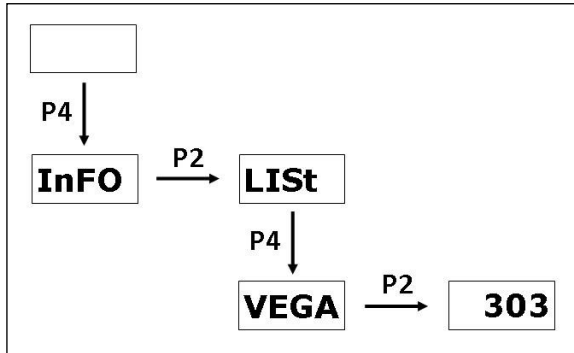

LOADING THE WIRELEX-CONFIGURED SYSTEM

When the Wirelex program, run on a personal computer, is used to generate the wireless system, it is programmed, through RS232, into the Sagittarius radio frequency PCB's flash memory *.

In order to make this new configuration usable, it must be loaded into the Vega PCB's flash memory **: this operation is now completed automatically by the translator module, but in previous models it had to be done manually by the installer through the LOAD command.

If this operation was not performed, after the radio frequency PCB was programmed, a load error (LOER) occurred.

Since the LOAD command has not been deleted from the device's interface, this paragraph has been retained for information purposes. A LOER message is still visualized after the radio frequency PCB is programmed and before the translator, automatically, loads the new configuration into the Vega PCB.

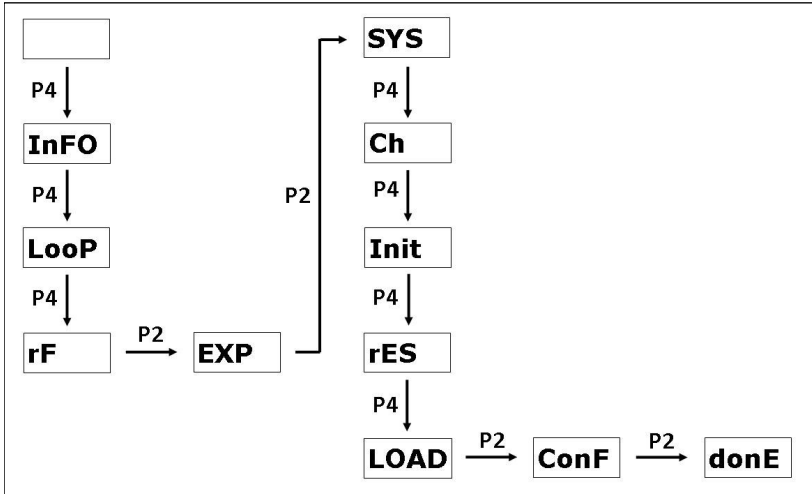

* The radio frequency PCB is the one connected directly to the two antennas.

** The Vega PCB is the one connected directly to the analogue loop.

WIRELESS SYSTEM'S DEVICES MANAGEMENT

Wireless devices can be added or deleted from the wireless system configuration of the translator. The translator's programmer menu, in order to perform such system management, is structured as described in the following paragraphs.

SENSOR AND BEAM DETECTOR DEVICES MANAGEMENT

Following is the procedure for reaching the fire sensor's sub-menu for adding or deleting this kind of device from the wireless system:

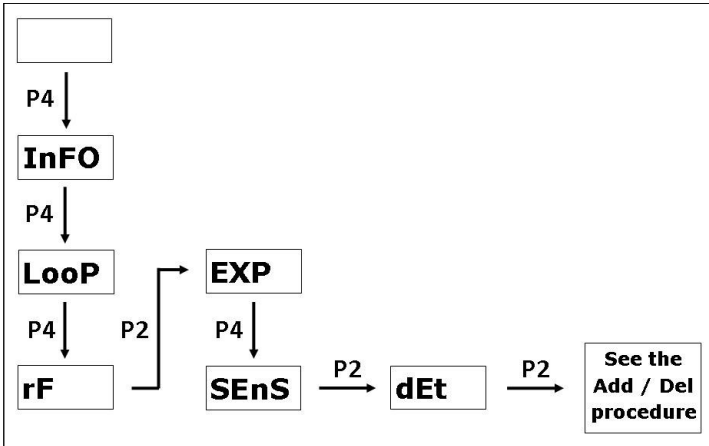

Refer to Appendix the installable sensing devices with this sub-menu.

B for a reference to

Following is the procedure for reaching the beam detector's sub-menu for adding or deleting this kind of device from the wireless system:

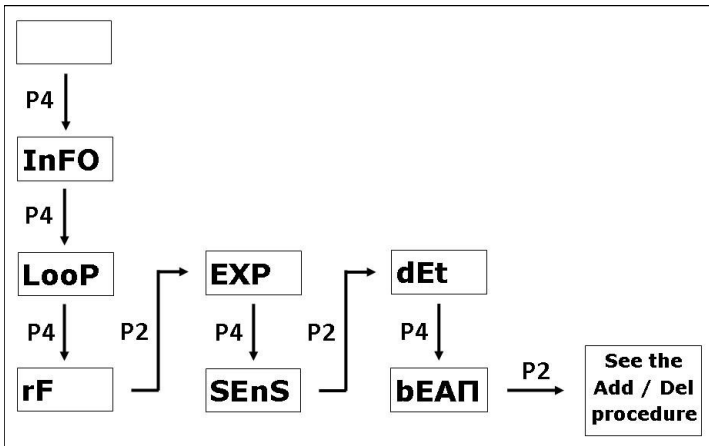

INPUT DEVICES MANAGEMENT

Following is the procedure for reaching the input device's sub-menu for adding or deleting this kind of device from the wireless system:

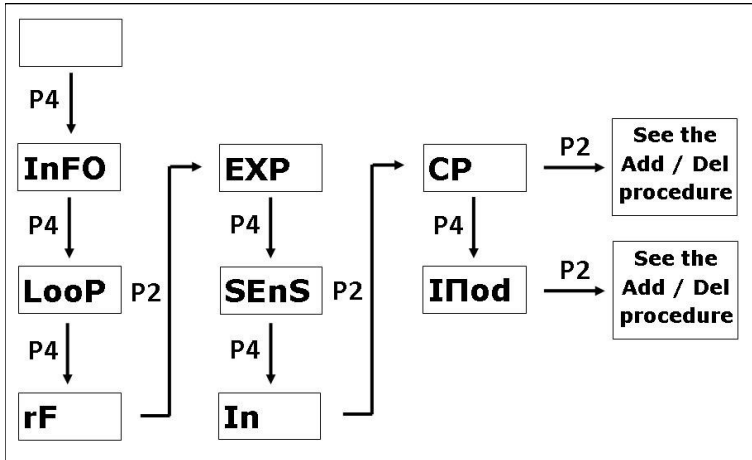

Refer to Appen-
reference to the installable input devices with this sub-menu.

dix B for a

OUTPUT DEVICE MANAGEMENT

Following is the procedure for reaching the output device sub-menu for adding or deleting this kind of device from the wireless system:

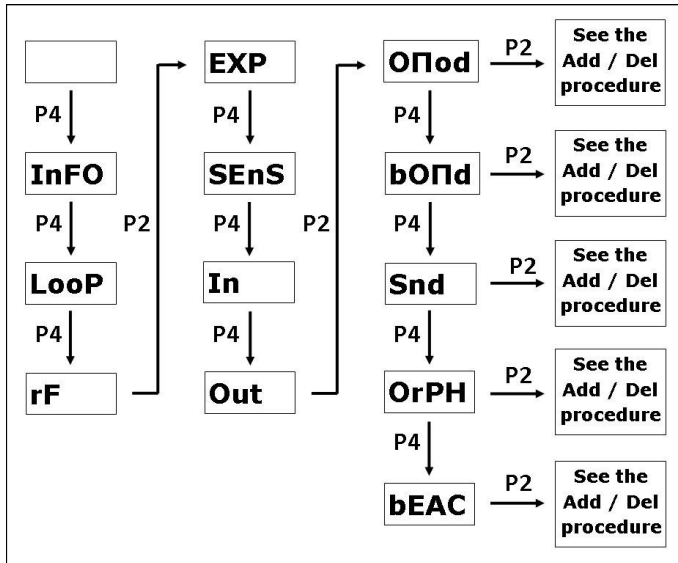

Refer to Appendix B installable output menu.

for a reference to the devices with this sub-

THE ADD / DEL PROCEDURE

Following is the common specific procedure for adding or deleting devices from the wireless system; it has been referenced in the previous procedures with the “see the Add / Del procedure” text box.

The ADD command procedure is performed in this way:

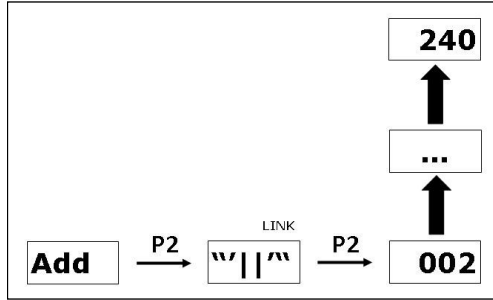

After the ADD command is performed, the translator waits the installer to trigger the linking of the child device by turning on the child device's "link-program switch" (see the specific installation manuals of these devices); during this phase, the LINK message is displayed and DL4 is switched on the translator.

After the linking for device's addition has been performed, the translator automatically assigns the next free contiguous address to it, starting the whole sequence from the next one assigned to the translator by the installer through the SA ("starting address") command. The automatically assigned address is signalled on the translator's display; this indicates that the child device is linked and has been achieved by the wireless system configured in the translator.

Following is the DEL ("delete") command procedure, applied to devices that are already present on the wireless configuration:

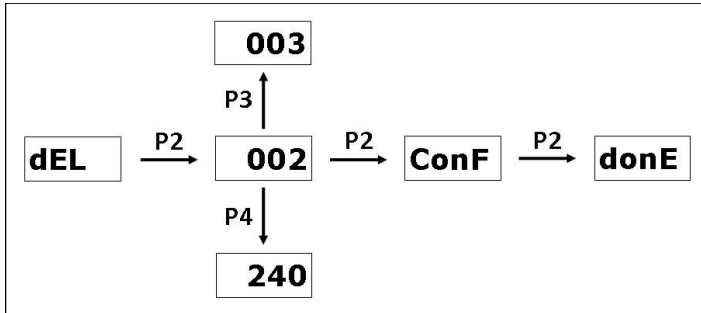

NOTE: This com- device from the translator, but not tion of the main control panel: the control panel's configuration needs to be manually updated or the wireless system needs to be re-learned by the control panel itself.

mand deletes a configuration of the from the configura-

Going further, you can use the CLRE command ("Clear Empty Spaces", see the CONFIGURATION'S DEFRAGMENTATION: THE CLRE COMMAND paragraph) and update or re-learn the wireless system on the Control Panel taking in to consideration the following warning:

WARNING!

! USING THE CLRE COMMAND WILL CHANGE MOST WIRELESS DETECTORS AND DEVICES ADDRESSES ON THE SYSTEM. MAKING NECESSARY TO MODIFY THE INSTALLATION MAP DRAWING AND TO UPDATE THE MAIN CONTROL PANEL'S CONFIGURATION OF THE SYSTEM. !

Following is the translator's response to the DEL command if NO devices of that type are present in the wireless configuration:

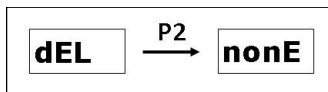

THE CLRE COMMAND

If one or more devices are removed from the wireless configuration (see the DEL command), empty address "spaces" remain, e.g. take a system addressed 001, 002, 003, 004, 005. The device addressed 003 is deleted from the configuration so that the only addresses remaining are 001, 002, 004, 005. Virtually speaking, address 003 is missing on the sequence; there is a gap in the addressing. By performing the CLRE command (means "clear empty spaces"), the gap is removed. The system addresses now used are 001, 002, 003 and 004.

Clearing the address gap/space is carried out in the Translator Module configuration and not on the main Control Panel. The Control Panel configuration will need to be updated to reflect the changes on completion of using the CLRE command.

WARNING!



USING THE CLRE COMMAND WILL CHANGE MOST WIRELESS DETECTORS AND DEVICES ADDRESSES ON THE SYSTEM. MAKING NECESSARY TO MODIFY THE INSTALLATION MAP DRAWING AND TO UPDATE THE MAIN CONTROL PANEL CONFIGURATION OF THE SYSTEM!



The following procedure is used for CLRE:

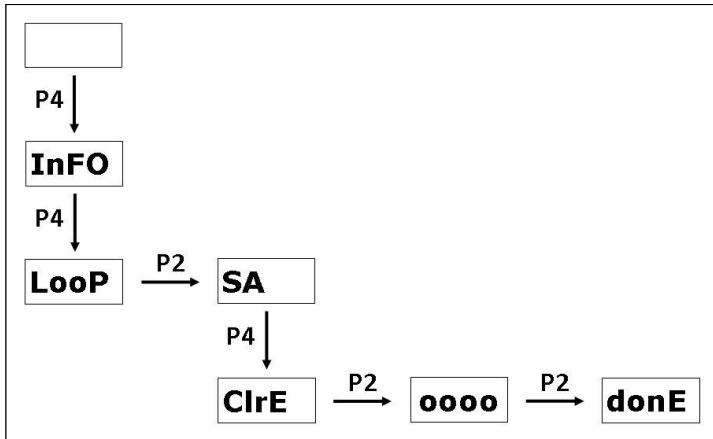

PART 5 - SIGNALLING, TESTING AND MAINTENANCE

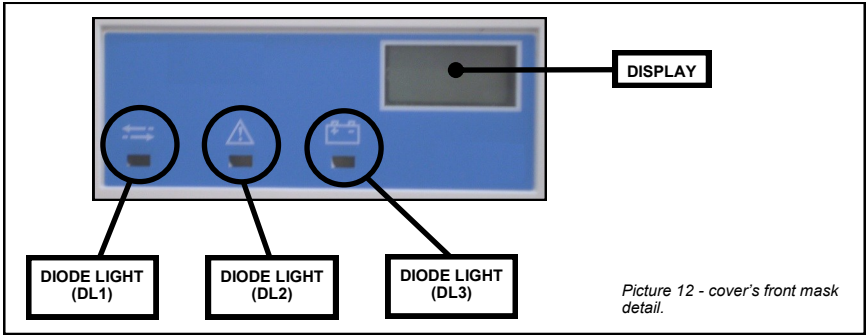

Picture 12 - cover's front mask detail.

TRANS-COVER'S FRONT MASK

LATOR

After the Translator Module cover has been closed, it is still possible to see DL1, DL2, and the display through the front mask of cover (see picture 12).

GENERAL FAULTS

The translator signals general fault conditions of itself and its child devices. To be more specific, general faults can be:

- a child device is not communicating anymore with the translator
- channel jamming is being deliberately performed in order to compromise wireless data interchange
- the Vega and Sagittarius PCBs are disconnected (the connecting ribbon cable must be securely connected)
- load error: the Sagittarius radio frequency PCB has been programmed, using Wirelex, with a new system configuration, but not the Vega PCB.
This fault is temporary and not persistent and disappears as soon as the new configuration is automatically loaded onto the Vega PCB by the translator itself.

In case of these faults, DL2 is switched on and a fault message is sent to the control panel.

BATTERY FAULTS

The translator signals child device battery fault conditions: if the main or secondary battery is low in charge, this event is signalled by the translator on the display, with the address and the indication whether the shortage occurs in the primary or secondary battery (see picture 13 and 14).

In case of this kind of fault DL3 is switched on and a fault message is sent to the control panel.

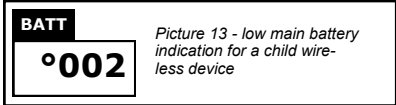

Picture 13 - low main battery indication for a child wireless device



Picture 14 - low secondary battery indication for a child wireless device

TAMPER FAULTS

The translator signals child device tamper events. If a tampering attempt is performed, this event is signalled by the translator on the display with the address of the child device and a little spanner icon on the right side (see picture 15).

In case of this kind of fault, a fault message is sent to the control panel.

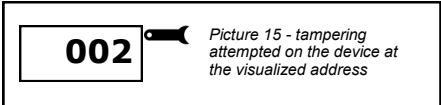

EXPANDER'S FAULTS

Expander's faults, connected to the translator, are signalled on the display; in these cases DL2 switches on. The EXP indication is shown on the display, followed by a numeric digit that indicates not an address, but the numeric sequential identification of the expander in the system; it can range from 1 to 7.

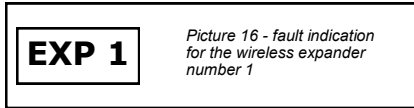

FATAL FAULTS

A fatal fault indicates a persistent and latched fault condition that can stem from a set of different causes like a linked child device having the link-program switch set on "SETUP / ASSESS ONLY" for long amount of time or a missing end of line resistor on a wireless child input module.

To solve this condition is necessary to solve the cause of the fault and to reset the system or from the translator (RES command) or from the control panel. If this is not sufficient, there could be a serious problem involving the faulty child device or the translator device itself: contact your supplier for support and an eventual substitution of the faulty device.

To remove this fault a "PROCESSOR RESET" must be carried out at the Control Panel.

FIRE EVENTS

The translator can signal fire events. If a child device indicates a fire event, this is signalled to the translator on the display with a message like in picture 17.

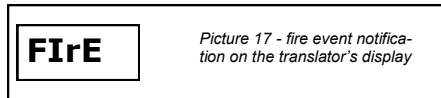

In this case a fire message is sent to the control panel.

DEVICE'S FAULT AND FIRE EVENTS REFERENCE TABLES

For a reference concerning how fault and fire events, related to every single wireless device type, are indicated by the translator, consult Appendix D.

FAULT AND FIRE EVENTS RESET

To reset the translator from fault or fire events it is necessary to:

- 1) solve the cause of the fire or fault events
- 2) one of these two actions can be performed:

- send the reset command from the main control panel: the translator, the wireless child devices and the whole system will reset successively
- reset the wireless system from the translator; the main control panel will, successively, exit the alarmed / fault condition if its triggering cause was exclusively detected in the associated wireless system.

TESTING

In order to test the functionality of the installed translator, it must be tested that the device relays data packages to the main control panel; by activating a wireless Manual Call Point or a sensor (**linked to the translator under test**), generate an alarm detection message that will be sent through the translator up to the control panel; the control panel will trigger an alarm condition.

After each test the control panel or the translator must be reset by its specific command.

All devices must be tested after installation and, successively, on a periodic basis.

MAINTENANCE

- 1) Before starting any maintenance work, isolate and disable the system, in order to avoid accidental and unwanted fault detection on conditions.
- 2) Remove the front cover from the translator's wall box.
- 3) Perform the planned necessary maintenance operations.
- 4) After the device has been serviced, reinstall correctly the translator cover on its main body, re-apply power to the system and check correct operation as described under the TESTING paragraph.

APPENDIX A - DISPLAY MESSAGES DEFINITIONS

The following list defines the messages used by the translator's display.

MAIN MENU

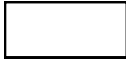

BLANK: this is the starting display; no command, menu or sub-menu is selected. If other messages are displayed, it is possible to reach this screen by pressing P1 an adequate number of times or by waiting 90 seconds without touching the keypad.



INFO: information gathering main menu. By proceeding from here it is possible to have information on the wireless system configuration and the Vega interface firmware's version.



LOOP: Vega loop interface's parameters setting main menu. By proceeding in this menu it is possible to set manually the translator's address and defragmentate the translator wireless system address configuration.



RF: radio-frequency's main menu. By proceeding from this menu it is possible to manage the wireless system configuration.

SUB-MENU



EXP: "expander" sub-menu; in this case "expander" refers solely to the translator's radio interface and not to an expander device. Contains the commands to select the system's identifier, select the operating channel, load a configuration generated with the Wirelex program or reset the system from fault or fire conditions.



SENS: sensor sub-menu: contains the commands to add or delete wireless fire sensors to the system.



DET: detectors sub-menu: contains the add and delete commands for adding or deleting a detector to or from the system.



BEAM: Beam detector sub-menu: contains the add and delete commands for adding or deleting this kind of device to or from the system.



IN: this sub-menu contains the sub-menus of the wireless input devices.



OUT: this sub-menu contains the sub-menus of the wireless output devices.



CP: this sub-menu contains the commands for adding or deleting wireless call points.

IMod

IMOD: this sub-menu contains the commands for adding or deleting wireless input modules.

OMod

OMOD: this sub-menu contains the commands for adding or deleting wireless output modules.

bOPd

BOMD: battery output module; with the commands of this sub-menu, this type of wireless, battery supplied output module can be added or deleted from the wireless system configuration. Those commands apply to the wireless remote indicator lamp too.

Snd

SND: sounder. This sub-menu contains the commands for adding or deleting wireless Sounders and Audio-Visual devices.

OrPH

ORPH: "Orpheus" voice annunciator . This sub-menu contains the commands for adding or deleting wireless annunciators.

bEAC

BEAC: beacon. This sub-menu contains the commands for adding or deleting wireless beacons.

COMMANDS

LIST

LIST: this command lists the configured wireless devices on the system; the user, selecting an address, will see the device associated to it; DL5 will switch on when a device type is displayed.

VEGA

VEGA: displays the firmware version of the translator's Vega analogue interface.

SA

SA: start address. This command permits the user to assign the Vega analogue address to the translator; it is also the starting address from which the configured child devices will be addressed.

ClrE

CLRE: "clear empty spaces". If devices are deleted from the configuration, unused addresses, or "empty address spaces", remain in the wireless configuration; this command refills those "spaces".

SYS

SYS: system. This command permits the setting of the system identification number.

Ch

CH: channel. This command permits the setting of the translator's operating channel.

Init

INIT: initialize. This command makes effective the changes made with the SYS and CH commands. **After having performed this operation, the actual translator's wireless system configuration will be erased.** Do not confuse this command with the RES command.

rES

RES: reset. This command resets the translator from fault or fire conditions. Do not confuse this command with the INIT command.

LOAD

LOAD: (OBSOLETE) the Sagittarius radio frequency PCB has been programmed, using Wirelex, with a new system configuration; now the Vega PCB is to be aligned to the new configuration through this command, in order to make it utilizable.

Add

ADD: Allows the addition of a wireless device to the translator's configuration.

dEL

DEL: Allows the deletion of a wireless device from the translator's configuration.

Conf

CONF: confirm. The execution of this command is requested as a confirmation of a previously performed operation.

Node

MODE: NOT YET USED.

MESSAGES

FIrE

FIRE: indicates a fire alarm sent by one of the configured devices.

002

TAMPER: one of the configured devices, having the address shown, has been tampered.

BATT

°002

low battery indication; the primary battery of the device at the displayed address is low.

BATT

o002

low battery indication; the secondary battery of the device at the displayed address is low.

LINK

\ " | | " "

LINK: the Translator is waiting to be linked to a wireless device. When this message is displayed, DL4 is switched on.

P002

P + ADDRESS: a wireless Photo Detector has been added to the Translator configuration with the displayed address.

m002

M + ADDRESS: a wireless Multi-Criteria Detector has been added to the Translator configuration with the displayed address.

H002

H + ADDRESS: a wireless Thermal Detector has been added to the Translator configuration with the displayed address.

002

BLANK + ADDRESS: only after the link message: a wireless device has been added to the Translator configuration with the displayed address.

Full

FULL: all configuration addresses of the translator have been used.

nonE

NONE: no items exist in the configured devices set.

0000

WAIT: the translator is performing an operation and communicates the user, with this display, to wait.

donE

DONE: a certain operation has been performed by the translator.

LOEr

LOER: (TEMPORARY) load error. The Sagittarius radio frequency PCB has been programmed, using Wirelex, with a new system configuration, but not the Vega PCB through the LOAD command.

EXP 1

EXP + NUMBER: indicates a fault on an expander present in the translator's wireless system; the subsequent number is not an address, but a sequential number univocally identifying the expander.

CONFIGURED DEVICE TYPES

The following messages are visualized with the performance of the LIST command, when the user wants to see the device type associated to a certain address; during their visualization DL5 switches on, in order not to confuse them with their homonymous sub-menus.

Pht

PHT: wireless photo detector.

Pult

MULT: multi-criteria, optical-thermal wireless detector.

thr

THR: thermal wireless detector.

bEAP

BEAM: beam detector.

CP

CP: wireless call point.

Snd

SND: wireless sounder.

IПod

IMOD: wireless input module.

OПod

OMOD: wireless output module.

bOПd

BOMD: wireless battery powered output module and wireless remote indicator lamp.

OrPH

ORPH: wireless "Orpheus" voice annunciator.

bEAC

BEAC: wireless beacon.

EXP

EXP: "expander"; refers to the translator's wireless interface and NOT to an expander. Indicates the device type for the translator.

APPENDIX B - LINKABLE DEVICES TO THE TRANSLATOR

Following is a list of radio devices linkable to the translator and their corresponding display as device types and sub-menu indication.

dEt	Wireless photo detector Wireless photo thermal detector Wireless thermal detector
bEAP	Beam detector
CP	Wireless call point
Snd	Wireless Wall Sounder Wireless Wall Sounder (Slow Whoop) Waterproof Wireless Wall Sounder Wireless Wall Sounder Beacon Waterproof Wireless Wall Sounder Beacon Wireless Base Sounder Wireless Base Sounder Beacon
IPod	Wireless supervised input module
OPod	Wireless output module
bOPd	Battery powered wireless output module Wireless remote indicator lamp
OrPH	Wireless voice annunciator
bEAC	Wireless beacon

APPENDIX C - MENU, SUB-MENU AND COMMAND STRUCTURE

The following scheme shows how the translator menu, sub-menu and command system is structured.

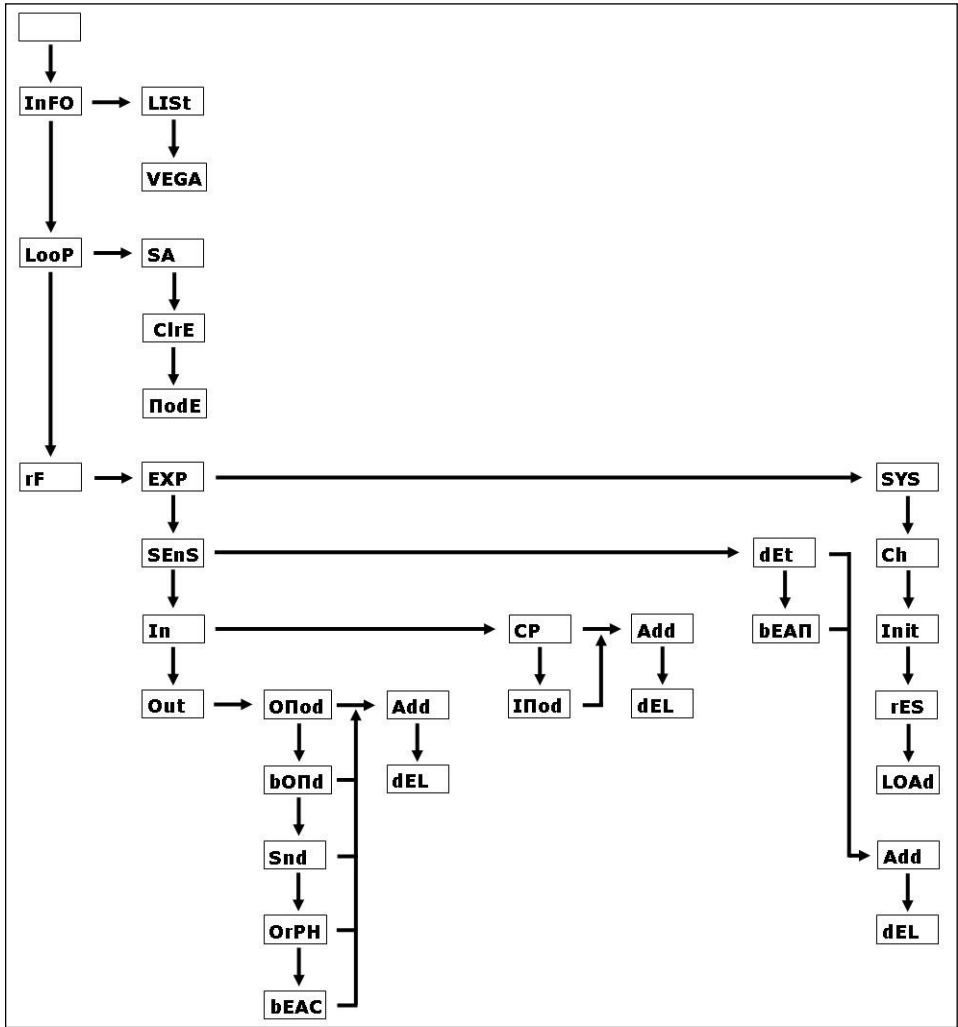

APPENDIX D - EVENTS AND INDICATIONS TABLE LIST

Following is an events and indications table list relative to each wireless device; it summarizes the indications given by the translator through display and LED outputs. Refer to Appendix A for a list reference of the possible displayable messages. If a wireless device is connected to the translator through other expanders (operating normally), indication of events remain unaltered as summarized below; but remember that if an expander primary power supply fails, the translator loses communication with it, together with all subsequent devices in the system (see below for the indication of this particular fault); if only the expander's secondary power supply fails the expander operates normally, but this event is adequately signalled on the translator and to the control panel (see below).

Wireless detector

Type of event	DL1	DL2	DL3	Display	Event signalled to control panel?
Missing link with the translator	-	Yes	-	Blank	Yes
Tamper fault	-	-	-	Tamper	Yes
Battery fault (primary or secondary)	-	-	Yes	Low battery	Yes
Fatal fault	-	-	-	Blank	Yes
Fire alarm (magnet test or smoke/heat alarming agent)	-	-	-	Fire	Yes

Wireless call point

Type of event	DL1	DL2	DL3	Display	Event signalled to control panel?
Missing link with the translator	-	Yes	-	Blank	Yes
Tamper fault	-	-	-	Tamper	Yes
Battery fault (primary or secondary)	-	-	Yes	Low battery	Yes
Fatal fault	-	-	-	Blank	Yes
Fire alarm (button pressing)	-	-	-	Fire	Yes

Wireless sounder

Type of event	DL1	DL2	DL3	Display	Event signalled to control panel?
Missing link with the translator	-	Yes	-	Blank	Yes
Tamper fault	-	-	-	Tamper	Yes
Battery fault (primary or secondary)	-	-	Yes	Low battery	Yes
Fatal fault	-	-	-	Blank	Yes

Wireless supervised input module

Type of event	DL1	DL2	DL3	Display	Event signalled to control panel?
Missing link with the translator	-	Yes	-	Blank	Yes
Tamper fault	-	-	-	Tamper	Yes
Battery fault (primary or secondary)	-	-	Yes	Low battery	Yes
Supervision detected fault (missing load or short circuit)	-	-	-	Blank	Yes
Fatal fault	-	-	-	Blank	Yes
Fire alarm (event triggered on the input channel)	-	-	-	Fire	Yes

Wireless output module

Type of event	DL1	DL2	DL3	Display	Event signalled to control panel?
Missing link with the translator	-	Yes	-	Blank	Yes
Tamper fault	-	-	-	Tamper	Yes
Power supply fault (device switches off and misses link with the translator)	-	Yes	-	Blank	Yes
Fatal fault	-	-	-	Blank	Yes

Battery powered wireless output module and wireless remote indicator lamp

Type of event	DL1	DL2	DL3	Display	Event signalled to control panel?
Missing link with the translator	-	Yes	-	Blank	Yes
Tamper fault (tamper switch not present)	-	-	-	Blank	No
Battery fault (primary or secondary)	-	-	Yes	Low battery	Yes
Fatal fault	-	-	-	Blank	Yes

Wireless voice annunciator

Type of event	DL1	DL2	DL3	Display	Event signalled to control panel?
Missing link with the translator	-	Yes	-	Blank	Yes
Tamper fault	-	-	-	Tamper	Yes
Battery fault (primary or secondary)	-	-	Yes	Low battery	Yes
Fatal fault	-	-	-	Blank	Yes

Wireless beacon

Type of event	DL1	DL2	DL3	Display	Event signalled to control panel?
Missing link with the translator	-	Yes	-	Blank	Yes
Tamper fault	-	-	-	Tamper	Yes
Battery fault (primary or secondary)	-	-	Yes	Low battery	Yes
Fatal fault	-	-	-	Blank	Yes

Wireless expander

Type of event	DL1	DL2	DL3	Display	Event signalled to control panel?
Missing link with the translator	-	Yes	-	Blank	Yes
Tamper fault (tamper switch present but is not operative)	-	-	-	Blank	No
Power supply fault (primary)	-	Yes	-	Blank	Yes
Power supply fault (secondary)	-	Yes	-	EXP + identification n°	Yes
Fatal fault	-	-	-	Blank	Yes

