

GENERAL DESCRIPTION

The conventional zone module is a device permitting to interface an analogue-intelligent addressable loop to a conventional detection zone. The analogue panel sees this device (and all the conventional sub-system) as a single addressed device on the loop. Conventional zone conditions as normal, open and short circuit and alarm are detected by this module and notified to the analogue control panel by the module itself; nevertheless this device is not capable of detecting the removal of a sensor from the conventional line.

The conventional zone module can be powered in different ways: either directly by the analogue detection loop or by an external power supply source. The conventional zone module is capable of monitoring its power supply (whether from the analogue loop or external) and measure the actual current that is flowing to the conventional zone line, giving the analogue control panel full control over the conventional sub-system and its status.

In addition to the above-said main feature, the conventional zone module is equipped with a non-supervised double pole relay output that can be used by the analogue control panel as an output module, for example, to provide a reset feature to some particular conventional systems.

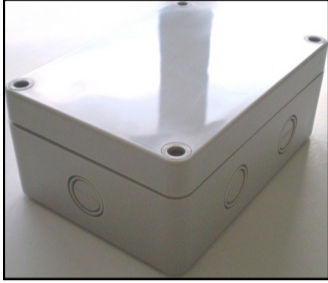

Picture 1 - Device overview

TECHNICAL SPECIFICATIONS *

Compatible communication / control protocol	Vega analogue-intelligent protocol
Vega protocol voltage range	from 4 V to 42 V
Device power supply voltage range (from loop)	20 V - 40 V
Device power supply voltage range (from external source)	20 VDC - 40 VDC
Conventional zone line applied voltage	Same as power supply
Current absorbed in standby by the device	500 µA
Current absorbed by device's red LED	6 mA
Current absorbed by device's green LED	4 mA
Current absorbed by device's amber LED	10 mA
End of line capacitor (EOL) characteristics	4.7 µF - 50 V
Alarm current limitation resistor's value range (RALL)	0 Ω - 1000 Ω
Relay nominal switching capacity (resistive load)	2 A - 30 VDC 0.5 A - 125 VAC
Relay max switching power	60 W - 62.5 VA
Relay max switching voltage	220 VDC 125 VAC
Relay max switching current	2 A
Compatible wire gauge range	0.5 mm ² - 2.5 mm ²
Operating temperature range	-10 °C - +55 °C
Maximum tolerated humidity	85% RH - no condensing
Ingress Protection rating	IP 54
Dimensions	130 mm x 93 mm x 58 mm
Weight	190 g

*Check latest version of document TDS-VMCZX for further data, obtainable from your supplier.

WHAT TO CHECK BEFORE INSTALLATION

Before installing the conventional zone module check these following items:

- This device must be installed following your national and / or international codes of practice and standards: check them before performing the installation of this device.

- This device is compatible only with control panels using the analogue-intelligent Vega protocol for fire security system data exchange and control; consult your control panel's documentation or consult your control panel's supplier for more information.

ADDRESSING

The first step to perform in installing this device is giving it an address, since the Vega protocol requires that the devices on the analogue loop are all addressed. One option is to use a hand-held programming unit, that can be bought from your distributor, through which you can program on the conventional zone module the desired address: please, refer to the programming unit's literature to gain more data about the practical know-how for this tool.

The second option is through the "automatic addressing" or "auto-addressing" feature that some Vega compatible control panels have: after the system is installed and wired, through this option it is possible to trigger a process that automatically addresses all the devices present in the analogue system; check your control panel's documentation or ask your supplier in order to determine whether the control panel has been implemented with such feature.

If you are using the programming tool, you can choose an address for this module between a range from 1 to 240; nevertheless remember that every single device on the same loop must have a unique number: just to give an example: you cannot address two devices with "34", since the control panel will signal a double address error.

PLACEMENT AND FIXING

To place and fix the conventional zone module perform in sequence the following steps:

- 1- Install and fix the device's box in the selected position using the appropriate screws and fitting them in their lodgment holes.
- 2- The output module box is designed with 6 cable entry knockout holes, distributed on the lateral sides of the device's box, allowing sealed, gland fitted cables to be connected to the device and, at the same time, to preserve the original IP protection rating. Fit the cable's gland (or glands) into the "knocked out" device box's cable entry.
- 3- Feed the cables into the box, giving them sufficient length for a secure connection.

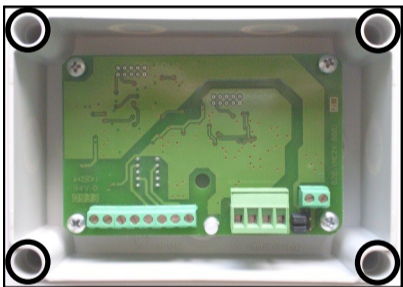

Picture 2 - Wall fixing screw holes

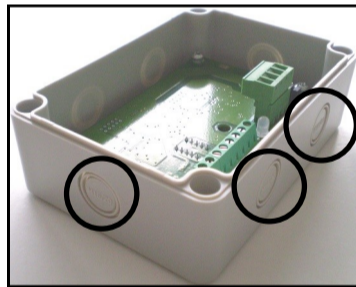

Picture 3 - Breakable holes for cable entry

WIRING CONNECTIONS

The conventional zone module's wiring phase of the installation has the following objectives:

- Connect the analogue-intelligent loop.
- Connect the conventional zone line.
- Connect the power supply source (either loop or external).
- Connect the relay output (optional).

WIRING WARNINGS

Five warnings about wiring:

- Perform any wiring operation with the power supply source and analogue loop inactive.
- Electrostatic sensitive device: observe precautions when handling and making connections.
- Connections to the terminals are polarity sensitive, thus, please, check them by referring to the wiring instructions of this manual.
- It is very important to install the supply power source selection jumpers correctly: check them by referring to the present manual.
- For each conventional detector add to its adaptor base an alarm current absorption limitation resistor (RALL), if the detector's characteristics require so.
- According to applied codes of practice and standards it could not be possible to install more than a certain number of sensors on the conventional line or zone of a single module (e.g.: for Italy more than 32 sensors require a short-circuit isolator module to be added to the line); consult and follow your standards and codes of practice in order to clarify this aspect.

WARNINGS AND LIMITATIONS

Our devices use high quality electronic components and plastic materials that are highly resistant to environmental deterioration. However, after 10 years of continuous operation, it is advisable to replace the devices in order to minimize the risk of reduced performance caused by external factors. Ensure that this device is only used with compatible control panels. Detection systems must be checked, serviced and maintained on a regular basis to confirm correct operation. Smoke sensors may respond differently to various kinds of smoke particles, thus application advice should be sought for special risks. Sensors cannot respond correctly if barriers exist between them and the fire location and may be affected by special environmental conditions. Refer to and follow national codes of practice and other internationally recognized fire engineering standards. Appropriate risk assessment should be carried out initially to determine correct design criteria and updated periodically.

WARRANTY

All devices are supplied with the benefit of a limited 3 years warranty relating to faulty materials or manufacturing defects, effective from the production date indicated on each product. This warranty is invalidated by mechanical or electrical damage caused in the field by incorrect handling or usage. Product must be returned via your authorized supplier for repair or replacement together with full information on any problem identified. Full details on our warranty and product return policy can be obtained upon request.



0051
21
HF-20-031CPR

Hyfire Wireless Fire Solutions Limited - Unit B12a, Holly Farm Business Park, Honiley, Warwickshire, CV8 1NP - United Kingdom

EN 54-17:2005
EN 54-18:2005

HFI-CZM-01

For use in compatible fire detection and alarm system

WIRING - LOOP CONNECTION

To connect the device to the analogue intelligent loop apply to the conventional zone module the following scheme:

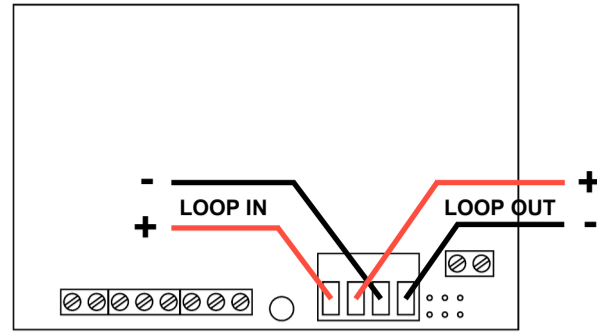

Picture 4 - Loop connection scheme

WIRING - POWER SUPPLY

If the conventional zone module is powered by an external source use the following connection scheme:

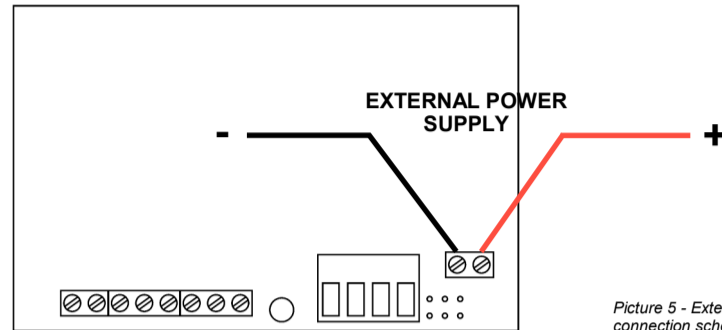

Picture 5 - External power supply connection scheme

If the device is power supplied directly by the loop, the two provided jumpers must be positioned as illustrated in the following picture:

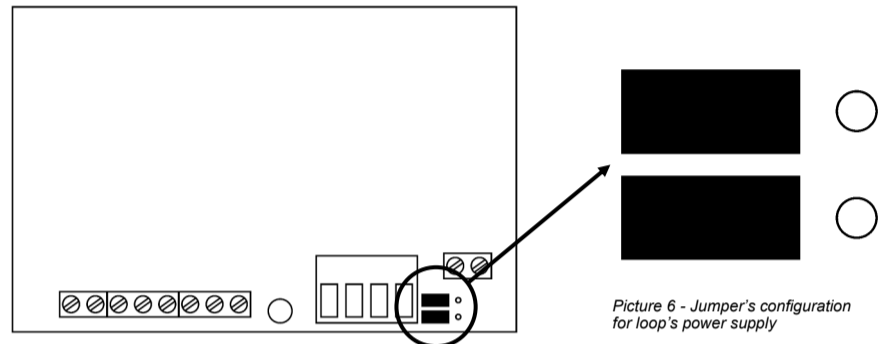

Picture 6 - Jumper's configuration for loop's power supply

If the device is power supplied by an external source, the two provided jumpers must be positioned as illustrated in the following picture:

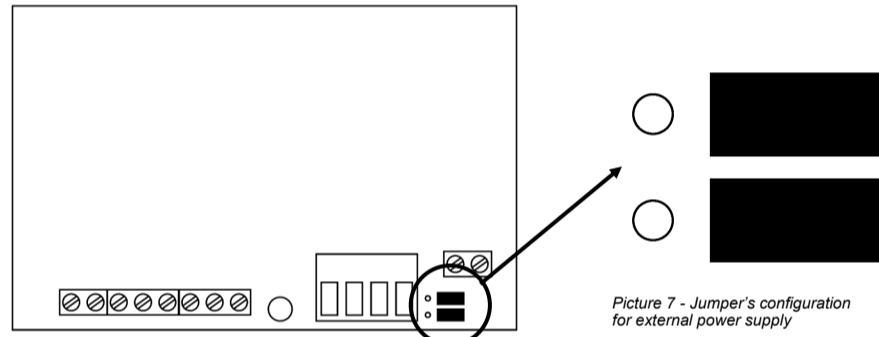

Picture 7 - Jumper's configuration for external power supply

WIRING - CONVENTIONAL LINE CONNECTION

Connect the conventional zone line by referring to the following pictures; the end of line component (EOL) must be installed at the end of the line and, if a capacitor is used, its polarities must be taken into account. An alarm current absorption limitation resistor for each conventional detector (RALL) must be added to the adaptor base, if the detector's characteristics require so.

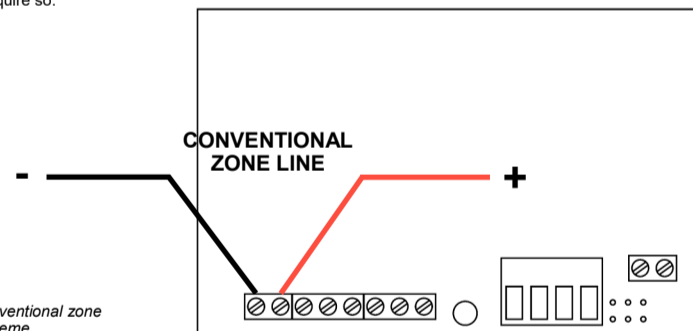

Picture 8 - Conventional zone connection scheme

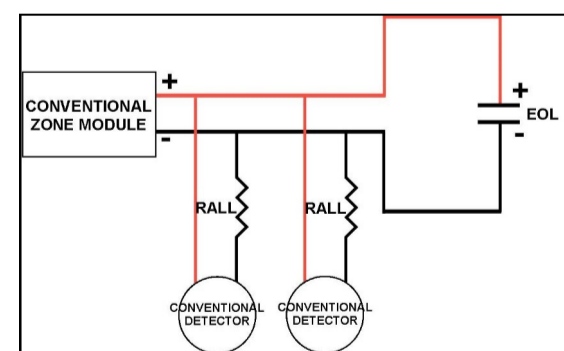

Picture 9 - Suggested conventional zone scheme with capacitive EOL

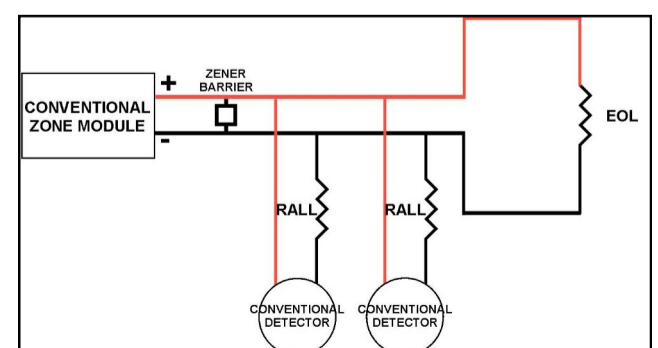

Picture 10 - Suggested conventional zone scheme with resistive EOL; ATEX normative compliant

WIRING - RELAY OUTPUT CHANNEL CONNECTION

The optional relay output channel is connected in the following way:

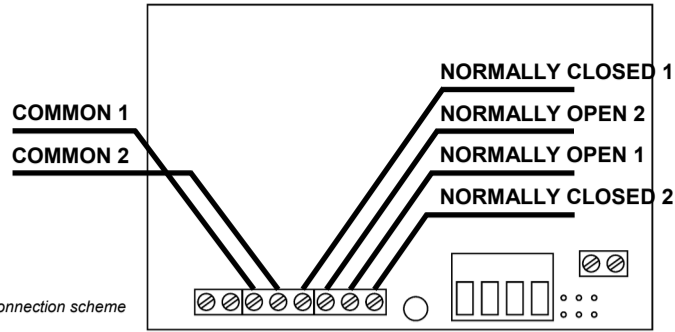

Picture 11 - Relay connection scheme

Please note that due to the non supervised nature of this output, only technologic devices can be connected to it (fire shutters hold / release devices and so on).

WARNING: when switching an inductive load, in order to protect the module from surges caused by counter-EMF, it is important to protect the relay contacts. A diode with a reverse breakdown voltage of at least ten times the circuit voltage (DC applications only) or a varistor (AC or DC applications) should be connected in parallel to the load.

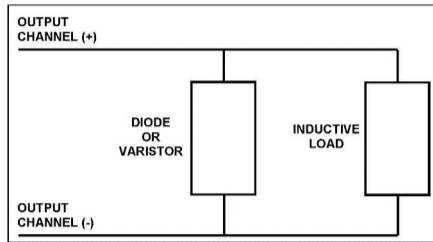

Picture 12 - Module protection circuitry's scheme for output's inductive load

WIRING - CONVENTIONAL SENSOR'S BASE WITH RESISTOR

This wiring scheme is used only when the detector's characteristics require that the absorbed current, in alarm condition, is limited by an external resistor (installed between the "R+" and "R" contacts of the adaptor base).

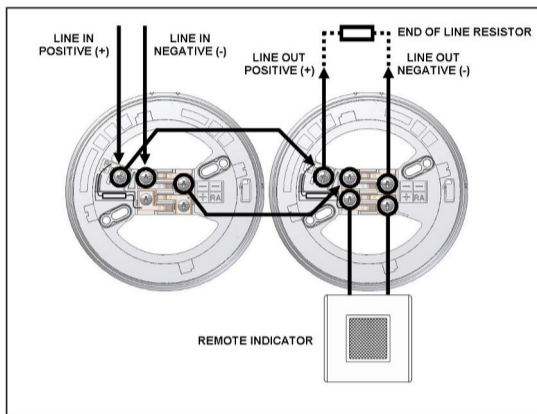

Picture 13 - Wiring used when the alarm current is limited by a limiting resistor on the mounting base.

WIRING - CONVENTIONAL SENSOR'S BASE (WITHOUT RESISTOR)

This wiring scheme is used only when the detector's characteristics DO NOT require that the absorbed current, in alarm condition, is limited by an external resistor.

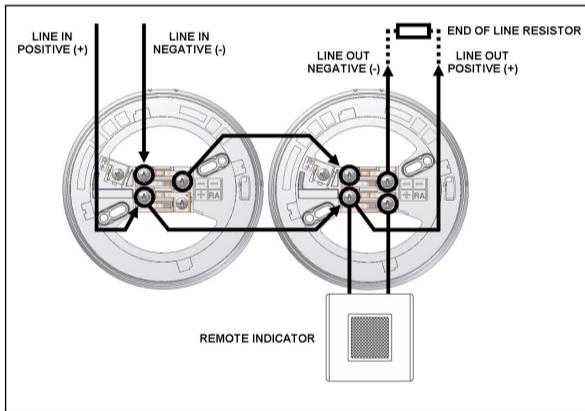

Picture 14 - Wiring used when the alarm current doesn't need to be limited.

PROGRAMMING THE CONVENTIONAL ZONE MODULE

The conventional zone module needs to be programmed before being operative. Programming consists in setting the following operating parameters for the conventional line controlled by the module itself:

Current limit: maximum supplyable current by the conventional zone module to the conventional zone line.

Alarm threshold: when the current, supplied by the conventional zone module, exceeds the alarm threshold value, the module falls into an alarm condition.

Reset duration: to reset the conventional zone line, the conventional zone module suspends to supply it with power for a certain amount of seconds: this amount of time is indicated here and is the "reset duration".

End Of Line (EOL) component type: if you are using a capacity or a resistor to terminate your conventional zone line, you must specify it in the conventional zone module programming.

All these parameters are summarized in a single decimal number that will be programmed into the conventional zone module through the use of the hand held programming unit and its "SET OP MOD" (set operating mode) function.

The programming value to be inserted must be first calculated by representing it in binary form; it is a number with 8 binary digits; see the following table: each column represents a single bit of the binary number that has to be defined:

Bit's numeric index:	7	6	5	4	3	2	1	0
Single bit's values:	128	64	32	16	8	4	2	1

Current limit and **Alarm threshold** values are defined by the first 4 bits, starting from the right: for more simplicity bits indexed 0, 1, 2 and 3; refer to the table at the right for a cross reference between these bits values and these programmable parameters; current limit and alarm threshold values are expressed in milliamperes (mA).

Bear in mind that **Current limit** and **Alarm threshold** values have a 5% tolerance.

Reset duration value is defined by bits indexed 4 and 5; refer to the following table for a cross reference between these bits values and this programmable parameter; **Reset duration** is expressed in seconds (s).

Bit's values	Reset duration (s)
0 0	0.5
0 1 (Factory default)	1
1 0	2
1 1	5

Bit's values	Current limit (mA)	Alarm threshold (mA)
0 0 0 0	6	2.5
0 0 0 1	6	2.5
0 0 1 0	6	4.5
0 0 1 1	10	2.5
0 1 0 0	10	5
0 1 0 1 (Factory default)	10	7.5
0 1 1 0	15	5
0 1 1 1	15	7.5
1 0 0 0	15	10
1 0 0 1	15	12.5
1 0 1 0	20	7.5
1 0 1 1	20	10
1 1 0 0	20	12.5
1 1 0 1	20	15

The used **End Of Line (EOL) component type** is defined by bits indexed 6 and 7; refer to the following table for a cross reference between these bits values and this programmable parameter's options:

Bit's values	EOL type	EOL specs	Minimum current required for EOL	Minimum applicable Alarm threshold
0 0 (Factory default)	Capacitor	4.7 μ F - 50 V	-	-
0 1	Resistor	18 k Ω	0.87 mA	2.5 mA
1 0	Resistor	8.2 k Ω	2.16 mA	4.5 mA
1 1	Resistor	4.7 k Ω	2.96 mA	7.5 mA

The before last column of the above table indicates the minimum required current that must pass through the EOL component in order to work correctly (this datum is valid only if a resistive EOL component is used); this value must be lower than the selected **Alarm threshold** value minus its 5% tolerance value; the last column of the table indicates the minimum selectable and applicable **Alarm threshold** value for each specified resistive EOL component.

The minimum resistive EOL required currents of the table above have been calculated on a 24 VDC EOL-applied voltage basis. If the above specified resistors are used, voltage must not drop below 20 VDC; if this happens, the conventional zone module can indicate a false open circuit condition on the conventional zone line. If lower voltages are needed, EOL resistors with lower values must be used in order to guarantee the minimum resistive EOL current requirements specified in the before last column of the table above.

When the product is brand new, factory default parameters are as in the following table:

Parameter description	Parameter value	Bit's values
Current limit	10 mA	0 1 0 1 Bits 0 - 3
Alarm threshold	7.5 mA	
Reset duration	1 s	0 1 Bits 4 - 5
End Of Line (EOL) component type	Capacitor (4.7 μ F - 50 V)	0 0 Bits 6 - 7

If we were, for example, to program the conventional zone module with these parameters, the number used for programming the device would be:

Bit's numeric index:	7	6	5	4	3	2	1	0
Single bit's values:	128	64	32	16	8	4	2	1
Programming number:	0	0	0	1	0	1	0	1

If you sum the single bit's values where the digit of the programming number is "1", you will have:

$$16 + 4 + 1 = 21$$

Decimal number 21 must be programmed through the hand-held programming unit into the conventional zone module in order to obtain the factory default parameters of the device.

DEVICE'S FEATURES - THE LED INDICATOR

The conventional zone module is equipped, on its internal PCB, with a three colour LED (red, green and amber) that provides visual indication as programmed on the control panel.

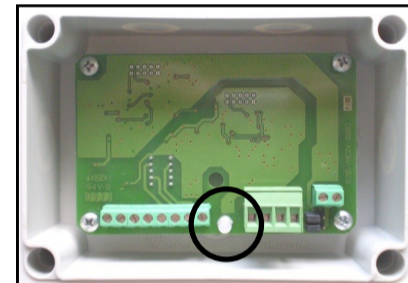

Picture 15 - LED indicator

DEVICE'S FEATURES - CONVENTIONAL ALARM DETECTION

When one or more devices on the conventional line fall in the alarm condition (sensors,...) or are activated (call points, input modules,...), the conventional zone module signals this event to the analogue control panel that will handle the situation as programmed.

DEVICE'S FEATURES - CONVENTIONAL LINE SUPERVISION

In addition to alarm detection, the conventional zone module supervises the conventional line for shorts and open circuit conditions; when these events occur, they are signalled to the analogue control panel that will handle the situation as programmed.

Please note that the zone module device is NOT capable of detecting the removal of a sensor from the conventional line.

DEVICE'S FEATURES - THE ANALOGUE LOOP'S SHORT CIRCUIT ISOLATOR

The conventional zone module has an in-built bidirectional isolator: it automatically opens when the voltage in the communication line falls below a fixed threshold in order to prevent a loop crash in case of a physical short circuit or an abnormal current consumption.

When activated, the in-built isolator will "cut out" the adjacent loop's section where the short occurred; on the other hand, all functions of the devices situated on opposite loop's section of the module (and the module itself) will be unaffected and operate normally.

When the line voltage rises again above the fixed threshold, the module will detect the removal of the cause of the fault condition and will automatically restore power to the isolated loop's section and its devices.

Short circuit event and recover from it are signalled by the conventional zone module to the analogue control panel.

TESTING THE DEVICE

After wiring, in order to test the functionality of the installed module, the following tests must be performed:

- Alarm a conventional sensor or activate an alarming device on the conventional line: the module must transmit the alarm event message to the analogue control panel that must react as programmed.

- Generate an open circuit on the conventional line: the module must transmit the open circuit event message to the analogue control panel that must react as programmed.

- Generate a short circuit on the conventional line: the module must transmit the short circuit event message to the analogue control panel that must react as programmed.

After each test reset the system from the control panel.

All devices must be tested after installation and, successively, on a periodic basis.

SEALING THE DEVICE WITH ITS COVER

After testing you can install the device's cover onto the module and, safely and securely, seal it by using the provided screws.

ISOLATOR SPECIFICATIONS	
Maximum rated continuous current with the switch closed - I_c max	350 mA
Maximum rated switching current (e.g. under short circuit conditions) - I_s max	350 mA
Maximum leakage current with the switch open (isolated state) - I_l max	7.4 mA
Maximum series impedance with the switch closed - Z_c max	0.11 Ω
The voltage at which the device isolates (i.e. switches from closed to open) - V_{SO}	11 V \pm 5%
The voltage at which the device reconnects (i.e. switches from open to closed) - V_{SC}	13 V \pm 5%