

GENERAL DESCRIPTION

The wireless expander is a module that is linked to a translator module or to another expander module permitting to expand the area coverage of the wireless system and / or permitting to install the wireless system in difficult radio environments. Communication and data exchange between the expanders, between the expander and its child devices and between the expander and its system translator is exclusively wireless via the "Sagittarius" bidirectional protocol. The expander module can be easily configured through (and solely) the "Wirelex-Fire" configuration software run on a personal computer; the computer is connected to the expander module through an RS232 serial cable. Unlike the vast majority of wireless devices, the expander module is powered by an external power source and not by batteries.

Note: The latest release of the wireless system configuration software is available from the manufacturer's website.

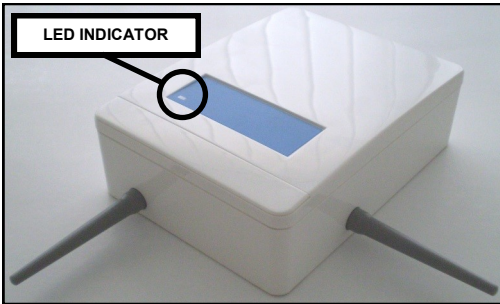

Figure 1 - Expander module overview.

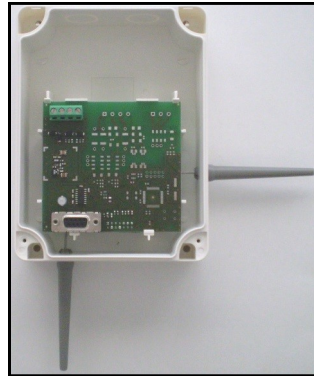
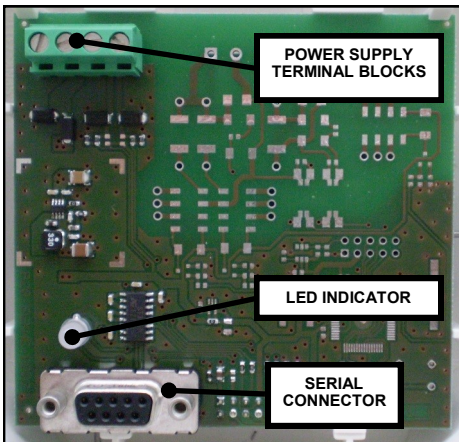

Figure 2 - Expander module inside view.

Figure 3 - Expander module PCB view.



TECHNICAL SPECIFICATIONS *	
Communication range with other expanders or the system's translator	600 meters (in open space)
Communication range with wireless child devices	200 meters (in open space)
Maximum number of expanders programmable on a single translator	7
Maximum number of expanders connected sequentially one after another	5
Maximum number of expanders connected to another single one	3
Operating frequency	868 MHz
Radio operating channels	7
Radiated power	5 dBm (3 mW)
Power supply voltage range **	9 Vdc - 30 Vdc
Primary and backup power supply voltage's lower fault threshold	11 +/- 0.5 Vdc
Expander current consumption	30 mA at 12 Vdc
Expander current consumption	15 mA at 24 Vdc
Operating temperature range	-30 °C - +50 °C
Expander's weight	300 g
Expander's dimensions (with antennas)	190 mm x 230 mm x 50 mm
Expander's dimensions (without antennas)	120 mm x 160 mm x 50 mm
Ingress protection rating	IP 51C
Required programming software	"Wirelex-Fire" revision 5.0 and successive

* Check latest version of document TDS-SGWEX for further data, obtainable from your supplier.

** Power source type ES1, PS2

DEVICE POSITIONING FOR RADIO COMMUNICATION PERFORMANCE AND STABILITY

The expander module must have a good radio communication with its wireless system's child devices and its translator. In order to achieve this, before positioning it and installing it, apply scrupulously the following points:

- Avoid installing the expander module close to:
 - equipment using large amounts of electrical current
 - large metal objects, structures or metal ceiling structures
 - fluorescent lighting fixings
 - computers, their cabling and network cabling.
- If there are other translators or expander modules, keep a distance between them of at least 2 meters. In general every installed radio device (child devices included) must have a minimum distance of at least 2 meters from each other.
- It is recommended to install the expander at a height from the floor of at least 2 - 2.5 meters.
- Install the expander perfectly flat on the wall.
- The expander must be installed perfectly straight on the wall; this means that the antenna under the device must be perpendicular to the floor and the antenna on the right of the device must be parallel to the floor.
- Environmental parameters (temperature, humidity and so on) must be in the ranges specified in the expander's technical specifications, which can be found at the beginning of this manual; this point applies, obviously, to all other wireless devices.
- After having installed the expander, make sure that its child devices (sensors, call points, etc.) are reached by a good, strong signal (refer to the single device's manuals) in their position of installation. Radio transmission ranges for the expander can be found in the technical specifications at the beginning of this manual.

- WHEN AT LEAST AN EXPANDER IS INVOLVED, USE ONLY THE PERSONAL COMPUTER'S "WIRELEX-FIRE" SOFTWARE FOR CONFIGURING AND ADMINISTERING THE SYSTEM! AVOID USING THE PUSH BUTTONS / DISPLAY INBUILT SYSTEM OF THE SYSTEM'S TRANSLATOR!

SURFACE INSTALLATION PROCEDURE

The expander's circuitry is already equipped with its own surface mounting box, designed with four 20 mm breakable entry holes (two at the top and two on the upper side of the rear of the box), allowing sealed, cable gland fitted, power supply cables to be connected to the device (see picture 4).

- Find a suitable location for the expander.
- Drill the required number of holes on the wall (see picture 5 for an indication of the screw inserting locations on the box and figure 6 for an indication of their distances between each other and their diameter).
- Prepare the cable openings on the box.
- Securely and adequately fix the device's box to the wall with adequate screws (DO NOT use the countersunk type).

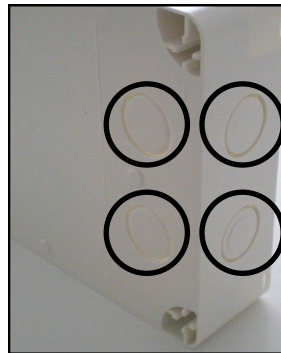

Picture 4 - breakable wire entry holes

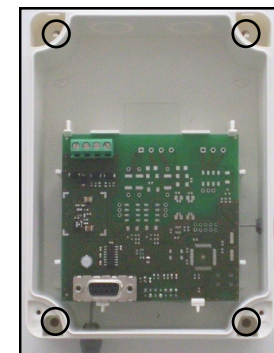

Picture 5 - wall fixing screw holes

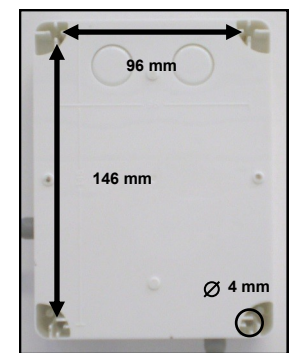

Picture 6 - distances between wall fixing screw holes and their diameter

EXPANDER'S WIRING

For wiring bear in mind those two points:

- refer to and follow national codes of wiring and cabling practice and other internationally recognized standards
- power supply terminals are polarity sensitive, so connect them adequately according to the following instructions.

Fit adequate cable glands (with an IP rating equal or greater than the IP rating of the expander module: see the TECHNICAL SPECIFICATIONS table) to power supply cables and eventual power supply monitoring cables, and apply them to adequately "knocked out" entry holes; successively feed the wires into the box, giving them a sufficient length to be connected to the device's terminals. If other knockout holes have been erroneously opened, seal them with blanking glands in order to maintain the device's original IP rating.
Connect the cables to the device's terminal blocks positioned on the inner PCB as per wiring scheme in picture 7 and 8.

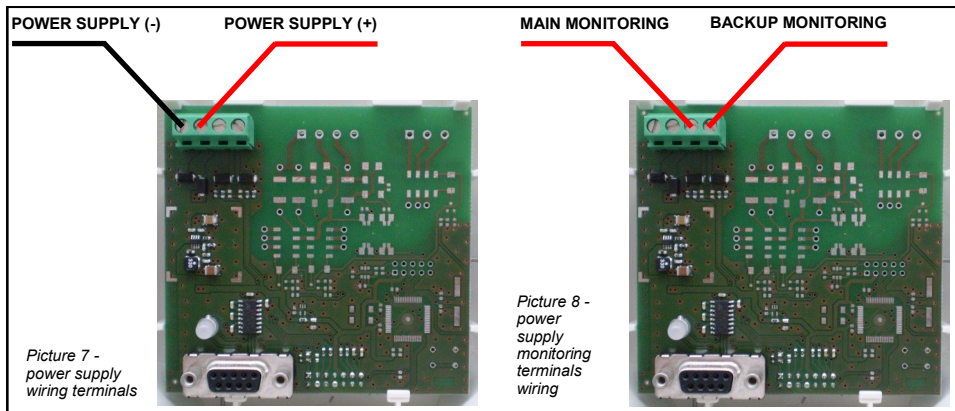

MAIN AND BACKUP MONITORING

As said before, the expander module can be powered only by an external power supply source. Power supply monitoring can be performed directly by the expander module itself through the main and backup (if a backup power source is used) monitoring terminals; if the power supply voltage drops under a certain value (see the TECHNICAL SPECIFICATIONS table) a fault message is sent to the control panel through the wireless system translator, notifying, consequently, a power shortage on the expander device.

MAIN MONITORING (MM): this terminal supervises the main power supply of an external power supply source.

BACKUP MONITORING (BM): this terminal supervises the backup power supply of an external power supply source.

Take care to program, with the "Wirelex-Fire" software, the activation of the power supply supervision feature during the programming of the expander device. On the other hand, if power supply supervision is NOT used, make sure that this feature is deactivated in order to avoid a fault condition (see the PROGRAMMING THE EXPANDER paragraph).

Figure 9 and 10 illustrate two schematic examples of power supply units with a power backup capability; MAIN MONITORING and BACKUP MONITORING outputs will be connected to the homonymous expander module's terminal blocks.

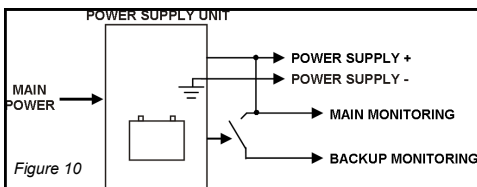
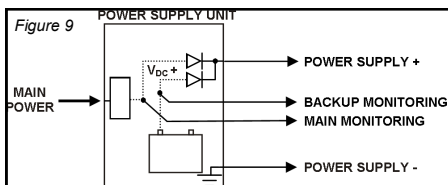

Device Status	Green LED	Red LED
Normal	Continuous glowing	-
Primary power supply fault	-	Continuous glowing
Backup power supply fault	Sequential green - red blinks	

Table 1

VISUAL LED INDICATOR

The expander module is equipped with a three-colour LED (red, green and amber) that provides visual indication for power supply conditions; this indicator is positioned on the PCB as illustrated in figure 3 and, when the device is closed, as illustrated in figure 1.

The table 1 illustrates the possible LED visual signals and their meaning.

PROGRAMMING THE EXPANDER MODULE

Two important things to know before starting:

- Use only the "Wirelex-Fire" software when configuring a wireless system with at least one expander involved; do not use the translator's inbuilt keyboard / display system.
- If power supply sources need to be monitored by the expander device, you must activate such monitoring feature when you setup the expander during programming.
- If power supply sources are NOT monitored by the expander device, such monitoring feature must be deactivated when you setup the expander during programming: a fault condition can occur if this action is not done.

Programming the expander, and in general programming and configuring the system, consists in:

1. Designing the wireless system on the "Wirelex-Fire" program.
2. Loading the so created system into the translator and the expander modules.
3. Linking the wireless child devices (wireless sensors, call point and so on) to their translator and expanders.

All programming phases require the personal computer, running "Wirelex-Fire", to be connected to the translator or expanders through an RS232 serial connection; for the expander module, its RS232 port is located onto its PCB, as showed in figure 3.

CLOSING THE EXPANDER BOX

1. Mount the expander's cover over its box, inserting the upper side first.
2. Securely screw the cover on the box by inserting the supplied screws into the front cover's holes.
3. Insert the plastic mask onto the front plastic cover in order to cover the screw's holes.

TESTING

In order to test the functionality of the installed expander, it must be tested that the device communicates with the control panel; by adequately acting on a call-point or a sensor (linked to the expander module under test), generate an alarm detection message that will be sent through the expander up to the control panel; the control panel will generate, consequently, an alarm condition. After each test the control panel must be reset by its specific command.

All devices must be tested after installation and, successively, on a periodic basis.

WARNINGS AND LIMITATIONS

Our devices use high quality electronic components and plastic materials that are highly resistant to environmental deterioration. However, after 10 years of continuous operation, it is advisable to replace the devices in order to minimize the risk of reduced performance caused by external factors. Ensure that this device is only used with compatible control panels. Detection systems must be checked, serviced and maintained on a regular basis to confirm correct operation. Smoke sensors may respond differently to various kinds of smoke particles, thus application advice should be sought for special risks. Sensors cannot respond correctly if barriers exist between them and the fire location and may be affected by special environmental conditions. Refer to and follow national codes of practice and other internationally recognized fire engineering standards. Appropriate risk assessment should be carried out initially to determine correct design criteria and updated periodically.

WARRANTY

All devices are supplied with the benefit of a limited 3 years warranty relating to faulty materials or manufacturing defects, effective from the production date indicated on each product. This warranty is invalidated by mechanical or electrical damage caused in the field by incorrect handling or usage. Product must be returned via your authorized supplier for repair or replacement together with full information on any problem identified. Full details on our warranty and product's returns policy can be obtained upon request.



Hyfire Wireless Fire Solutions Limited - Unit B12a, Holly Farm Business Park, Honiley, Warwickshire, CV8 1NP - United Kingdom

EN 54-25:2008
EN 54-18:2005
HFW-EM-01

For use in compatible fire detection and alarm system