

GENERAL DESCRIPTION

The Door Holder is a battery-powered wireless device used for holding fire doors open. It interfaces directly with the fire system and the release mechanism is activated when a command is received from the wireless translator or when the push-button is pressed.

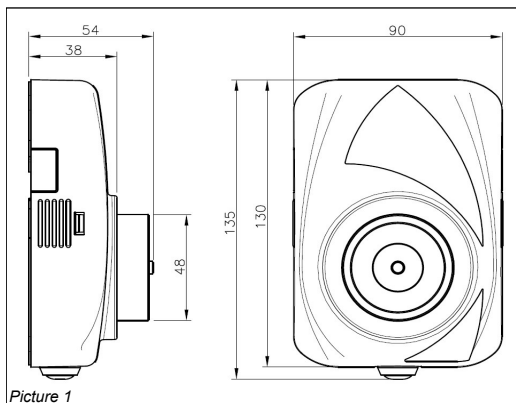

Picture 1

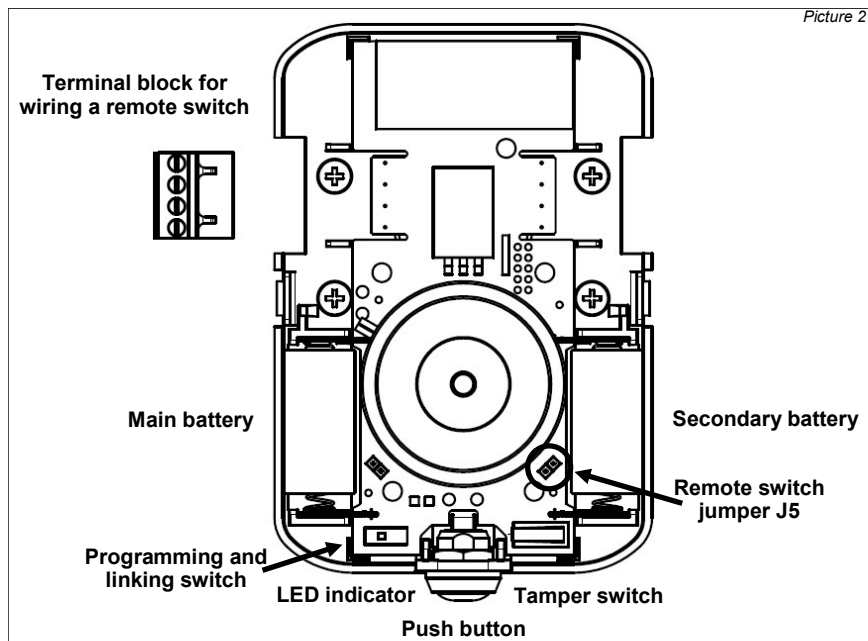

Picture 2

TECHNICAL SPECIFICATIONS *	
Operating frequency	868 MHz
Max radiated power	12dBm (16mW)
Radio signal's modulation type	FSK
Operating frequency channels	7
Device's communication range with its parent translator or expander in open space	200 m
Operating temperature range	-10°C to +55°C
Max tolerated humidity (non condensing)	95% RH
IP rating	IP30
Retaining force	200N
EN 1155 classification	3-5-5-1-1-0

Table 1

* Check latest version of document TDS-DH100 obtainable from your supplier for further data.

BATTERY SPECIFICATIONS	
Main battery type	CR123A (3V & 1.2Ah)
Secondary battery type	CR123A (3V & 1.2Ah)
Batteries service life	> 7 years *
Reserve service life	> 100 days *

Table 2

* When a low battery condition is indicated, main and secondary batteries must be changed together.

The lifespan value refer to the device being programmed with a control signal transmission period of 32 seconds.

VISUAL LED INDICATOR

A bi-color LED indicator is used to indicate the statuses as listed in table 3. The LED indication is visible only when the device cover is open. For further information, check the latest version of document TDS-DH100 obtainable from your supplier.

Detector's status	LEDs indication
Power up	1 second GREEN , then 4 X 0.5 second RED
Link success	1 second GREEN
Link failure	1 second RED
Normal condition	LEDs off
Battery 1 fault	0.1 second ORANGE blink, then 5 seconds off
Battery 2 fault	0.1 second GREEN blink, then 5 seconds off
Both batteries fault	0.1 second ORANGE , then 5 seconds off 0.1 second GREEN , then 5 seconds off
General fault	sequential ORANGE / GREEN 0.5 second blinking
Tamper fault	LEDs off
Lost link with wire to wireless translator / wireless expander	LEDs off

Table 3

PROGRAMMING AND LINKING

To configure the Door Holder in the wireless system perform the following procedure either from the translator's interface or from the Wirelex software:

1. Move the "link-program" switch to position ON (see picture 3)
2. Insert the batteries into its holder (the visual LED indicator switches on accordingly (see "Power-up" in table 3))

Ensure that both battery polarities are correct!!!

3. When the translator module is set to "linking-mode" and starts searching for a new device, move the switch to the OFF position. The device starts to communicate when the configuration is completed. The LED switches on accordingly (see "Programming and linking to the system" in table 3).

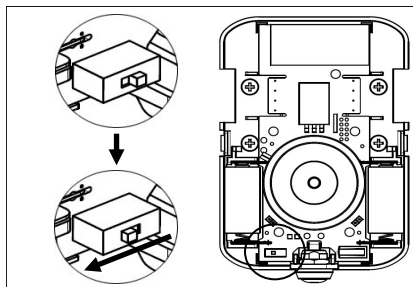

Picture 3

COMMUNICATION QUALITY ASSESSMENT

After a successful linking operation, to assess the wireless communication quality with the translator/expander module, set the "link-program" switch in the ON position; the device's LED will indicate the communication quality by blinking according to table 4.

Always remember to reposition the switch to 1 after the assessment operation: device will not work operatively while the switch is set to the ON position.

Communication quality	Assessment	Indication
No communication	Fail	Two red blinks
Communication quality: 0dB - 10dB (Mark 2)	Poor	One red blink
Communication quality: 10dB - 20dB (Mark 3)	Medium - Low	One green blink
Communication quality: 20dB - 30dB (Mark 4)	Good	Two green blinks
Communication quality: >30dB (Mark 5)	Excellent	Two green blinks

Table 4

INSTALLATION INSTRUCTIONS

1. Make sure the Programming and Linking procedure has been completed
2. Remove the device cover and both batteries to access the screw holes
3. Find an appropriate position for the device according to the door size
4. Use the device itself or the frame indicated in the manual page for the drilling position
5. Screw the device using appropriate screws according to the mounting surface
6. Insert the batteries and close the device cover
7. Attach the catch plate making sure it is aligned with the magnet
8. Gently open the door and press it against the back of the catch plate in order to align the surfaces
9. Mark appropriately the catch plate position with a pencil on the door.
10. Release the catch plate by pressing the button and use it for marking the drilling position
11. Screw the catch plate to the door using appropriate screws
12. Make sure the system is working correctly

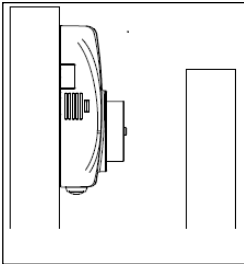

Step 3

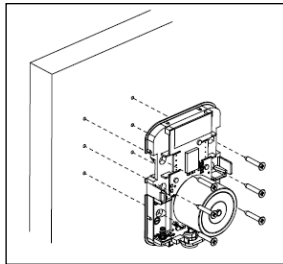

Step 4-5

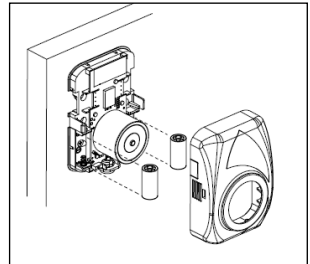

Step 6

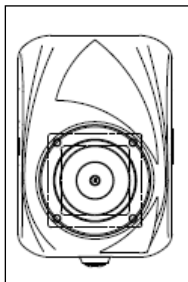

Step 7

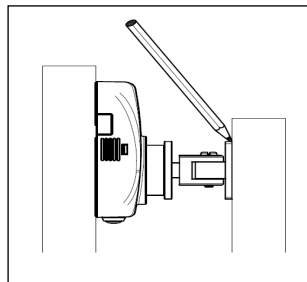

Step 8-9

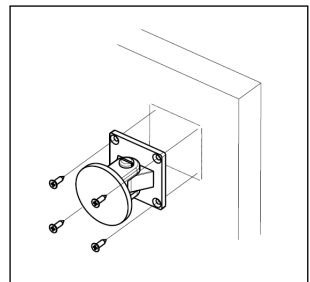

Step 10-11

Warning: do not attach the door to the magnet of the device if the Programming and Linking procedure has not been completed and if the batteries are not correctly placed. The device must be in normal operating mode in order to release the door!

BATTERY FAULTS

In case of a battery fault the door is released automatically and a "battery fault" message is sent to the control panel. Please replace the batteries and verify that the device goes in normal operation mode.

Warning: always use new batteries when replacing the old ones!

TAMPER DETECTION FEATURE

A tamper detection switch is fit on the product so that it sends a message to the control panel every time that the cover is removed. For this reason assure that the front cover is perfectly closed.

TESTING

To test the functionality of the Door Holder proceed as follows:

1. After completing the installation, linking and programming attach the door to the device.
2. Press a call point or stimulate a sensor installed in the system to generate in the control panel an alarm status.
3. Verify that the door is released after a maximum time equal to the supervisory time configured for the device.
4. Reset the control panel so that it deactivates the device's output and attach the door to the device.
5. For local testing press the push button at the bottom of the device and verify that the door is released.

All devices must be tested after installation and successively, on a periodic basis. Always attach the door after testing the device.

REMOTE SWITCH WIRING INSTRUCTIONS

1. Make sure the magnetic device and switch are installed on the door frame according to the instructions indicated in the corresponding Manual
2. Screw the two out-coming wires in position 1 and 2 of the terminal block
3. Insert the terminal block in the device PCB contacts (left or right side as convenient)
4. Place the cup on jumper J5 and reset the device either through the transiator or by removing the batteries
5. Break out the appropriate side on the cover and close the device

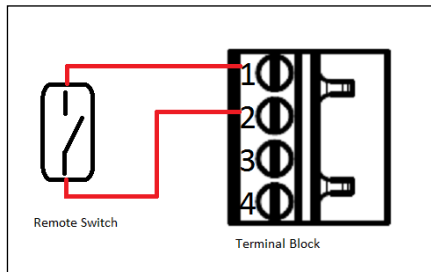

Step 2

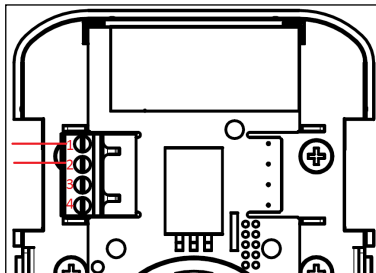

Step 3

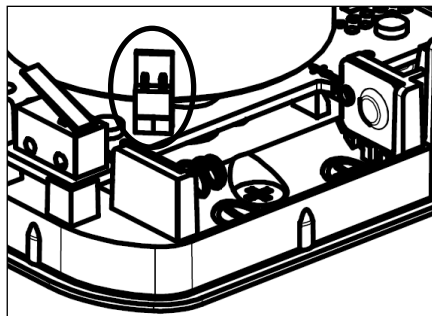

Step 4

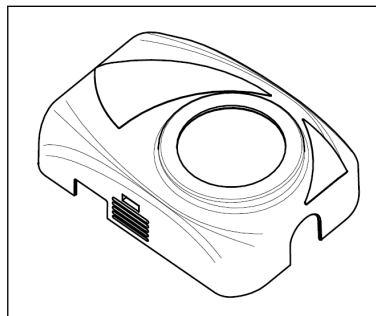

Step 5

REMOTE PUSH BUTTON WIRING INSTRUCTIONS

1. Make sure the device is properly installed and the push button position has been fixed according to the needs
2. Screw the two out-coming wires in position 1 and 4 of the terminal block. N.B.: if a remote switch is being installed two wires must be fit together in position 1 of the terminal block
3. Insert the terminal block in the device PCB contacts (left or right side as convenient)
4. Break out the appropriate side on the cover and close the device

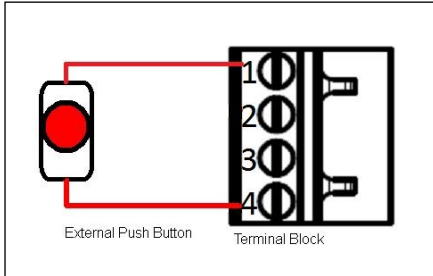

Step 2

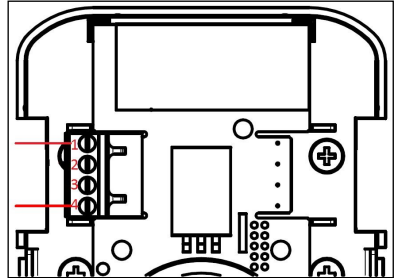

Step 3

WARNINGS AND LIMITATIONS

Our devices use high quality electronic components and plastic materials that are highly resistant to environmental deterioration. However, after 10 years of continuous operation, it is advisable to replace the devices in order to minimize the risk of reduced performance caused by external factors. Ensure that this device is only used with compatible control panels. Detection systems must be checked, serviced and maintained on a regular basis to confirm correct operation. Smoke sensors may respond differently to various kinds of smoke particles, thus application advice should be sought for special risks. Sensors cannot respond correctly if barriers exist between them and the fire location and may be affected by special environmental conditions. Refer to and follow national codes of practice and other internationally recognized fire engineering standards. Appropriate risk assessment should be carried out initially to determine correct design criteria and updated periodically.

WARRANTY

All devices are supplied with the benefit of a limited 5 years warranty relating to faulty materials or manufacturing defects, effective from the production date indicated on each product. This warranty is invalidated by mechanical or electrical damage caused in the field by incorrect handling or usage. Product must be returned via your authorized supplier for repair or replacement together with full information on any problem identified. Full details on our warranty and product's returns policy can be obtained upon request.



0051 /0479

22

HF-DHR-CPR

ARGUS ITALY S.R.L. - Via C. Goldoni, 8 -
Cologno Monzese, 20093 Milano - Italy

EN 1155:2003

HFW-DHR-01

For use in compatible fire detection and
alarm system

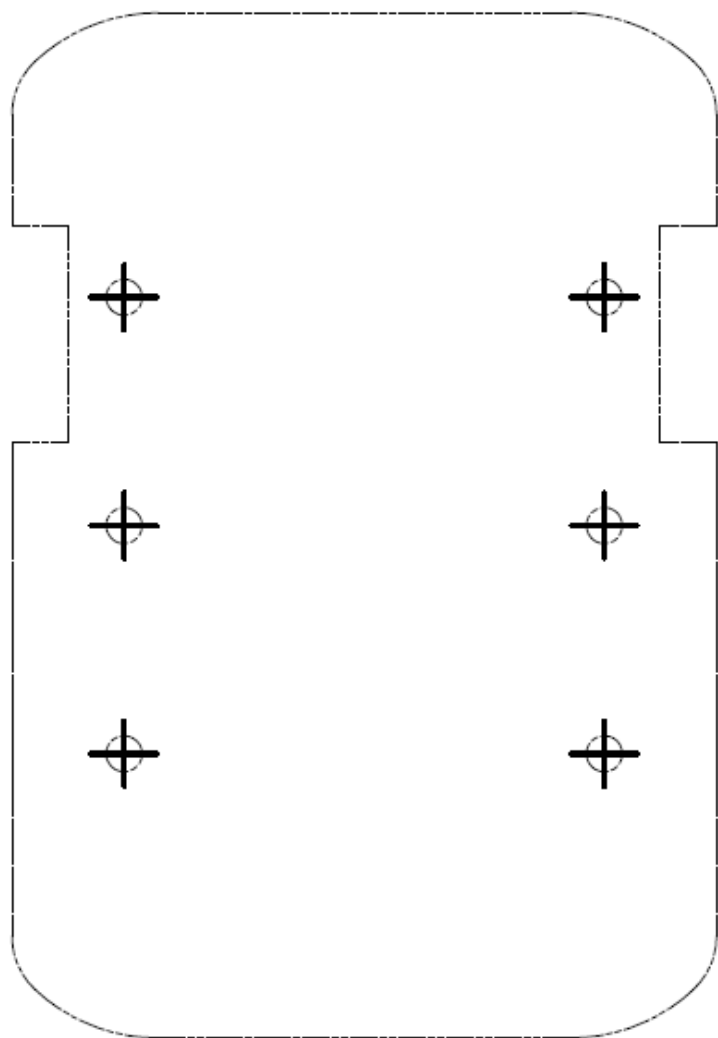

Template for fixing drilling to the wall flange